

5209015COM 4 Drawer Closet Storage

systembuild™
EVOLUTION

Date of Purchase ___ / ___ / ___
Lot Number:

B345209015COM0

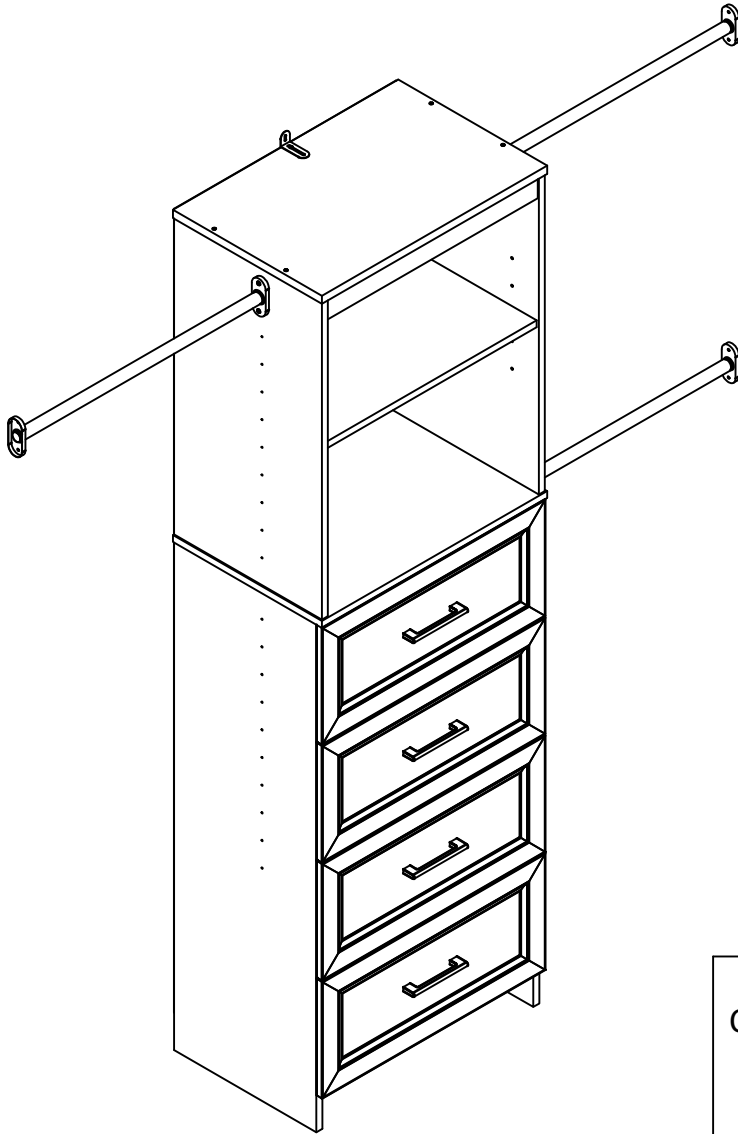

Do Not Return This Product!
Contact our customer service team for help first.
Call: 1-800-489-3351 (toll free)
Monday-Friday 9am - 5pm CST
Visit: www.systembuild.com

THIS INSTRUCTION BOOKLET CONTAINS **IMPORTANT** SAFETY INFORMATION. PLEASE READ AND KEEP FOR FUTURE REFERENCE.

Secure Your Furniture

Keep your home and family safe with the wall anchor kit that is included with the product.

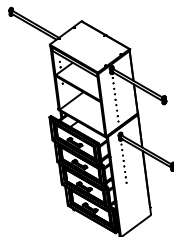

Serious or fatal crushing injuries can occur from tipping furniture.

WARNING: Manufacturer assumes no liability for improper installation or excessive loads placed on screws or bracket. This wall anchor is not a substitute for proper adult supervision.

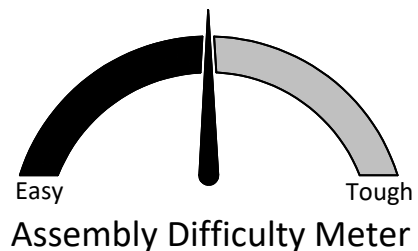

For the latest information on SystemBuild products follow us at Ameriwood Home



Contact Us!

Do NOT return this product!

Contact our friendly customer service team first for help.

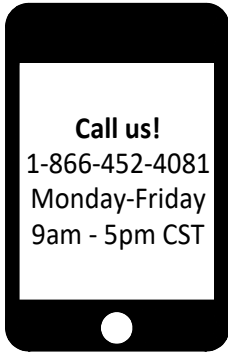

Visit systembuild.com to view the limited warranty valid in the U.S. and Canada.

Assembly Tips



Helpful Hints

PEOPLE NEEDED FOR ASSEMBLY: 1-2

- Open your item in the area you plan to keep it to avoid excessive heavy lifting.
- Identify, sort and count the parts before attempting assembly.
- Compression dowels are lightly tapped in with a hammer.
- Slides are labeled with a **R** (right) and **L** (left) for proper placement.
- Make sure to always face the point on the top of the Cam Lock towards the outer edge.
- Use all the nails provided for the back panel and spread them out equally.
- Back panel must be used to make sure your unit is sturdy.
- Do NOT use harsh chemicals or abrasive cleaners on this item.
- Never push, pull, or drag your furniture.

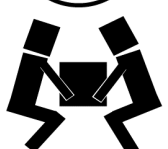

Before You Start

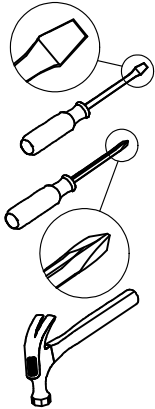
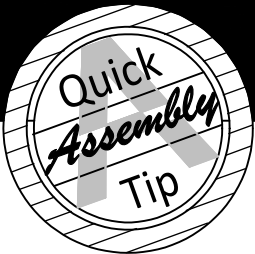

- ✓ Read through each step carefully and follow the proper order
- ✓ Separate and count all your parts and hardware
Parts are labeled on the surface or edge of the part
- ✓ Give yourself enough room for the assembly process
- ✓ Have the following tools: Flat Head Screwdriver, #2 Phillips Head Screwdriver and Hammer
- ✓ Caution: If using a power drill or power screwdriver for screwing, please be aware to slow down and stop when screw is tight. Failure to do so may result in stripping the screw.

Cam Lock Fastening System

This Cam Lock Fastening System will be used throughout the assembly process.

1

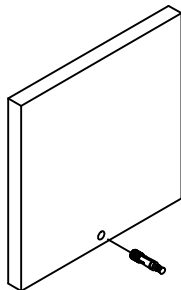

Press CAM BOLT into hole.

2

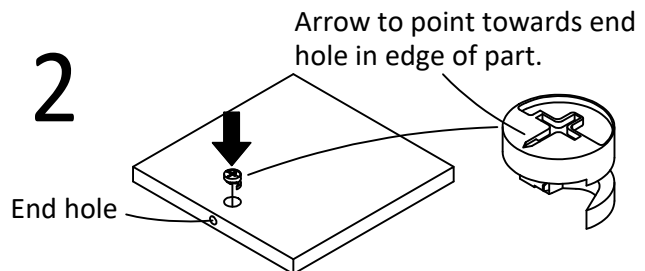

Press CAM LOCK into hole.

3

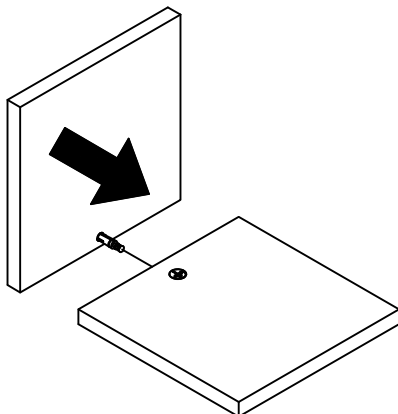

Press parts together so CAM BOLT inserts into edge hole.

4

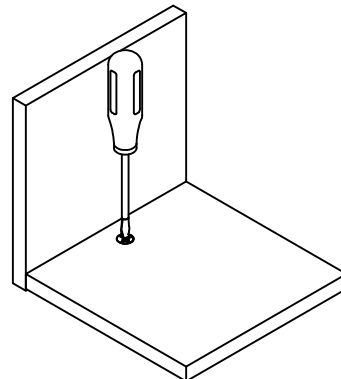

Using a screwdriver, turn the CAM LOCK clockwise to lock the CAM LOCK and CAM BOLT into their holes and fastening parts together.

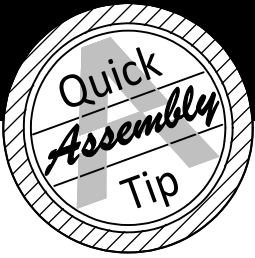

Before You Start

Please Note:
You may need to lightly tap the wood dowels into the holes during your assembly process.

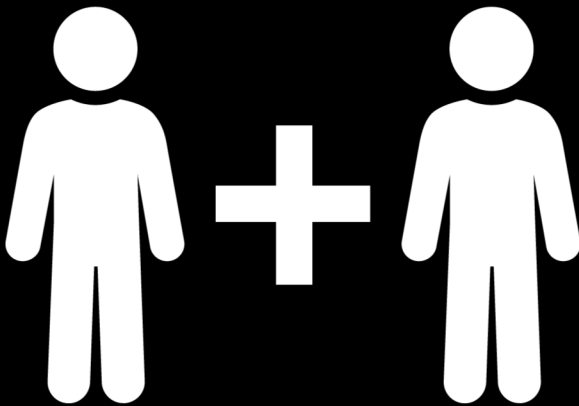
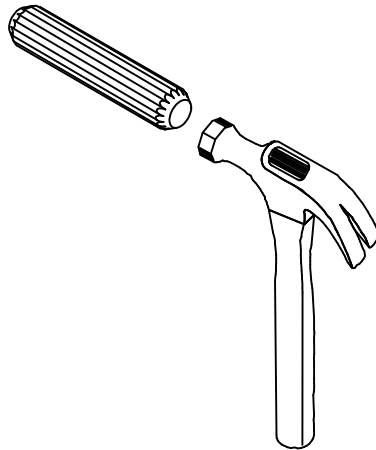

2 PEOPLE NEEDED FOR ASSEMBLY

**2 PERSONAS NECESITADAS
PARA LA ASAMBLEA**

**2 PERSONNES NÉCESSAIRES
POUR L'ASSEMBLAGE**

CAUTION: Failure to use 2 people for assembly could result in unit damage or personal injury.

PRECAUCIÓN: Si no se utilizan 2 personas para el ensamblaje, se pueden producir daños en la unidad o lesiones personales.

ATTENTION: Échec d'utiliser 2 personnes pour l'assemblage peut causer du dommage au meuble ou causer des blessures.

Board Identification

Not actual size

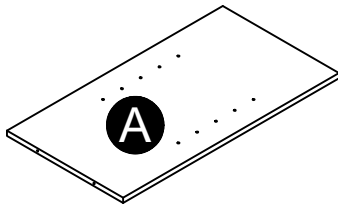

Left Upper Panel
35209015010

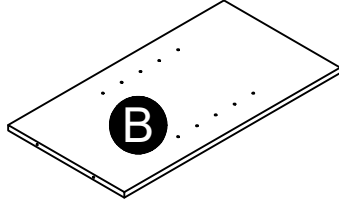

Right Upper Panel
35209015020

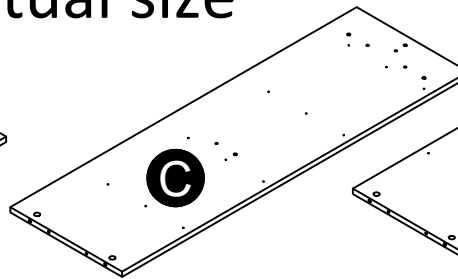

Left Lower Panel
35209015030

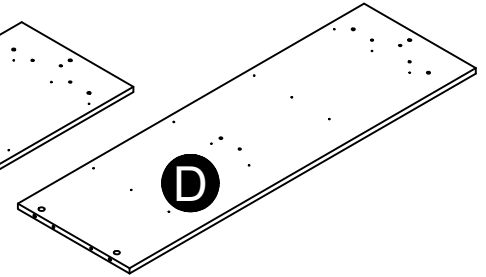

Right Lower Panel
35209015040

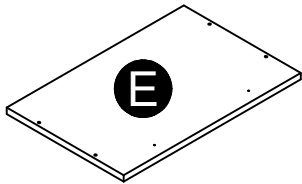

Top
35209015050

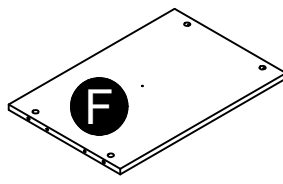

Bottom
35209015060

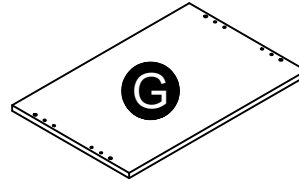

Center Shelf
35209015070

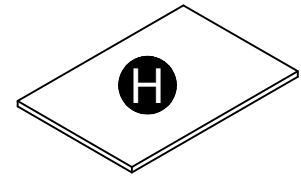

Adjustable Shelf
35209015080

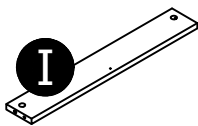

Kick
35209015090

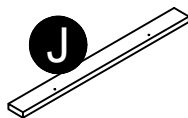

Top Rail
35209015100

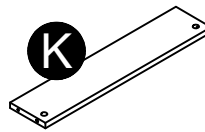

Support
35209000110

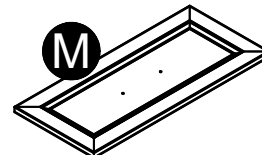

Drawer Front (X4)
37587015130



Left Drawer Side (x4)
39991167346410L

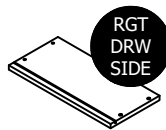

Right Drawer Side (x4)
39991167346410R



Drawer Back (x4)
39991167051217B



Drawer Bottom (x4)
39991337052310D

Board Identification

Not actual size

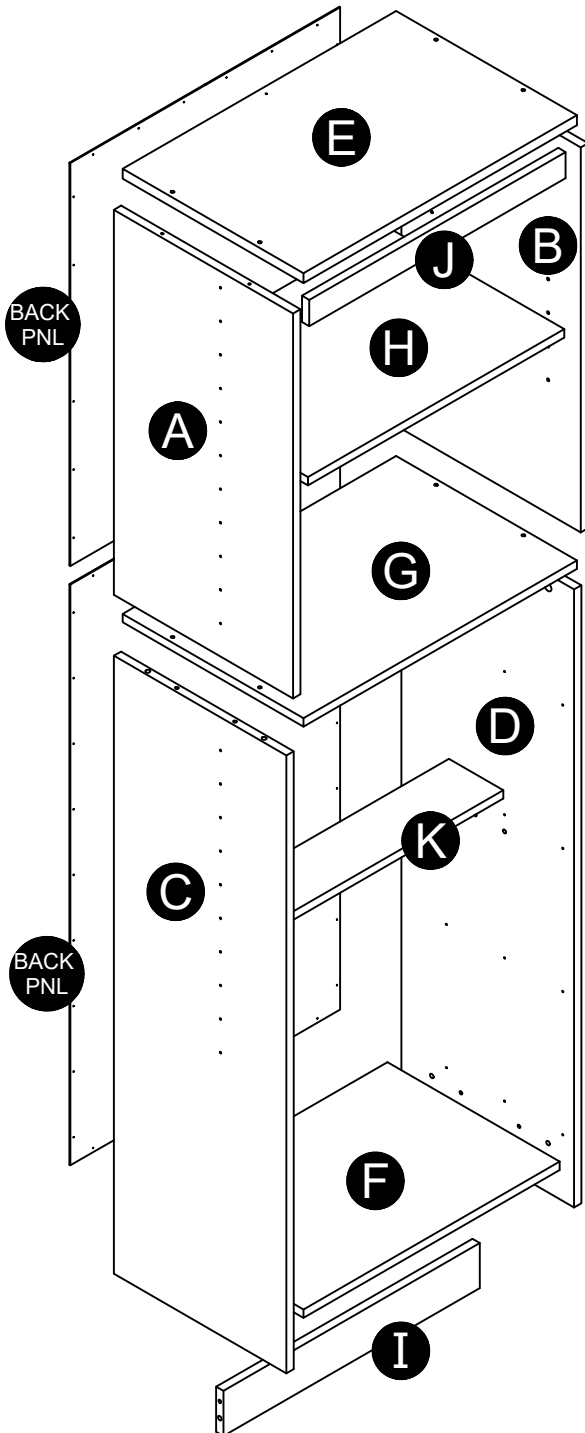

Upper Back Panel
K520901500

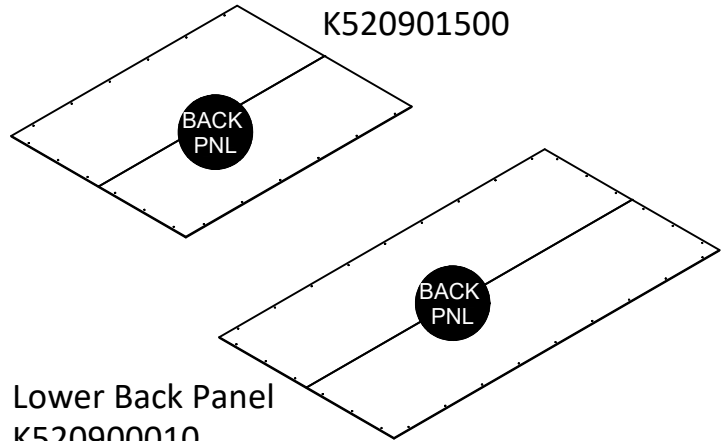

Lower Back Panel
K520900010

These pieces are paperboard construction. They are not made from wood, but are required for the assembly of your unit.

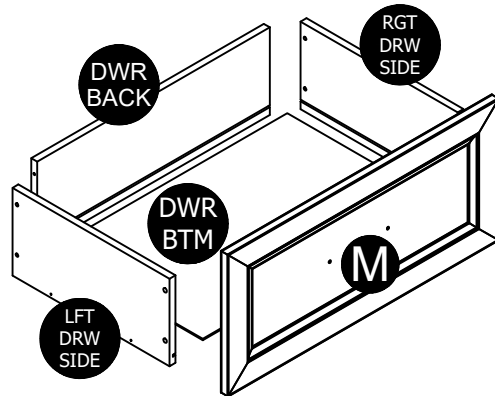

Part List

Actual Size

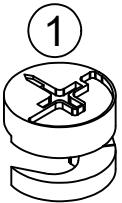

(x12)
#A22700
cam lock

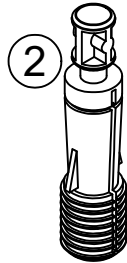

(x12)
#A22710
cam bolt

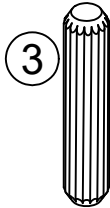

(x12)
#A21670
wood dowel



(x40)
#A11080
7/16" screw

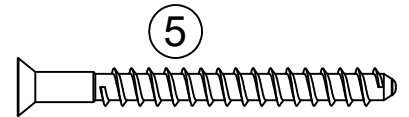

(x8)
#A23030
confirmat screw

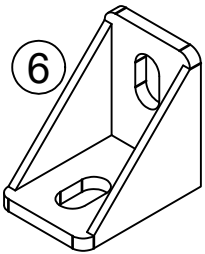

(x3)
#A53510
angle bracket

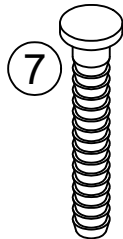

(x16)
#A21975
drive fastener



(x38)
#A12120
7/16" screw

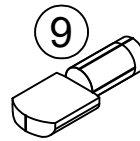

(x4)
#A80250
shelf support



(x8)
#A17010
3/8" bolt



(x6)
#A12700
7/8" pan head



(x48)
#A21110
nail

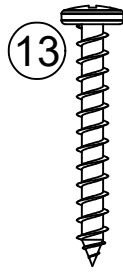

(x6)
#A13020
1-1/4" pan head



(x6)
#A20940
wall anchor

Part List

Not actual size

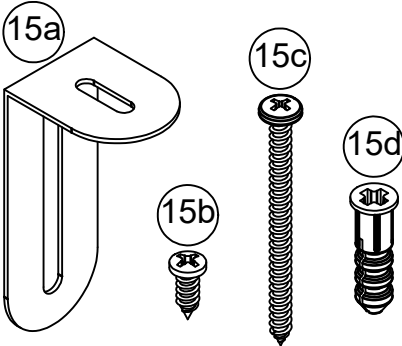

(x1)
15 #A84050
safety bracket

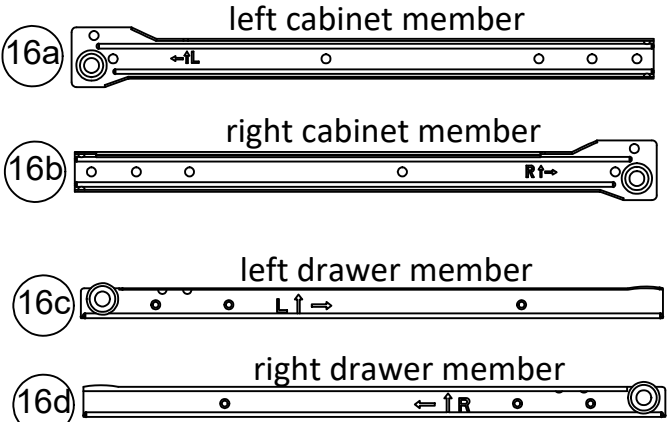

(x4)
16 #A56770
slide

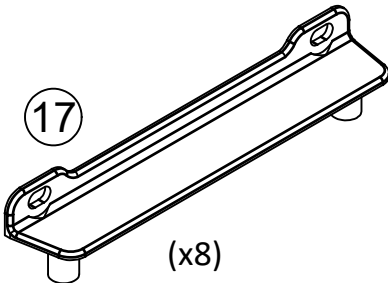

(x8)
17 #A54520
drawer bracket

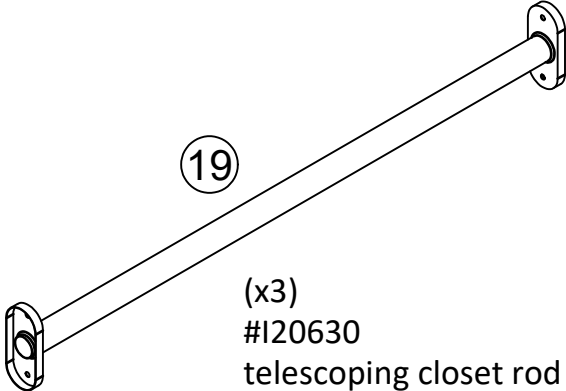

(x3)
19 #I20630
telescoping closet rod

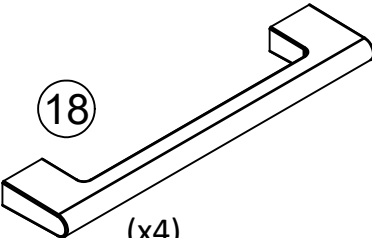

(x4)
18 #A50435
handle

STEP 1

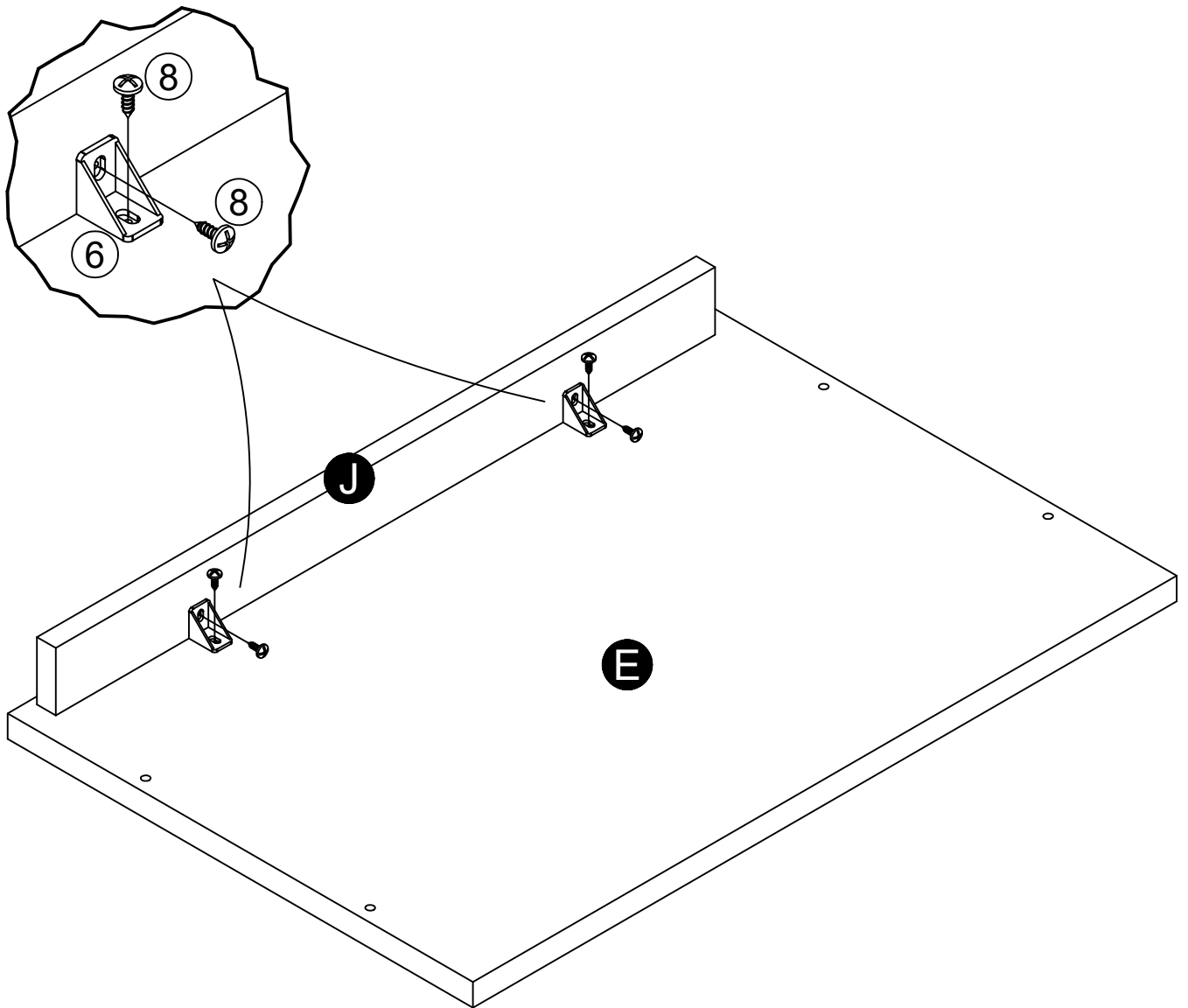
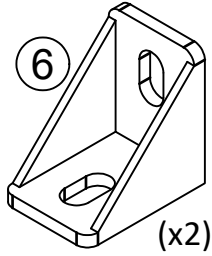
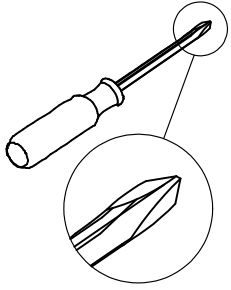

STEP 2

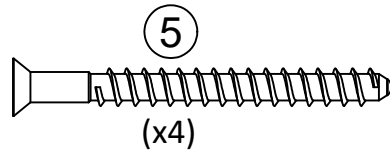
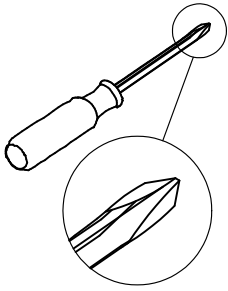

finished edges face up

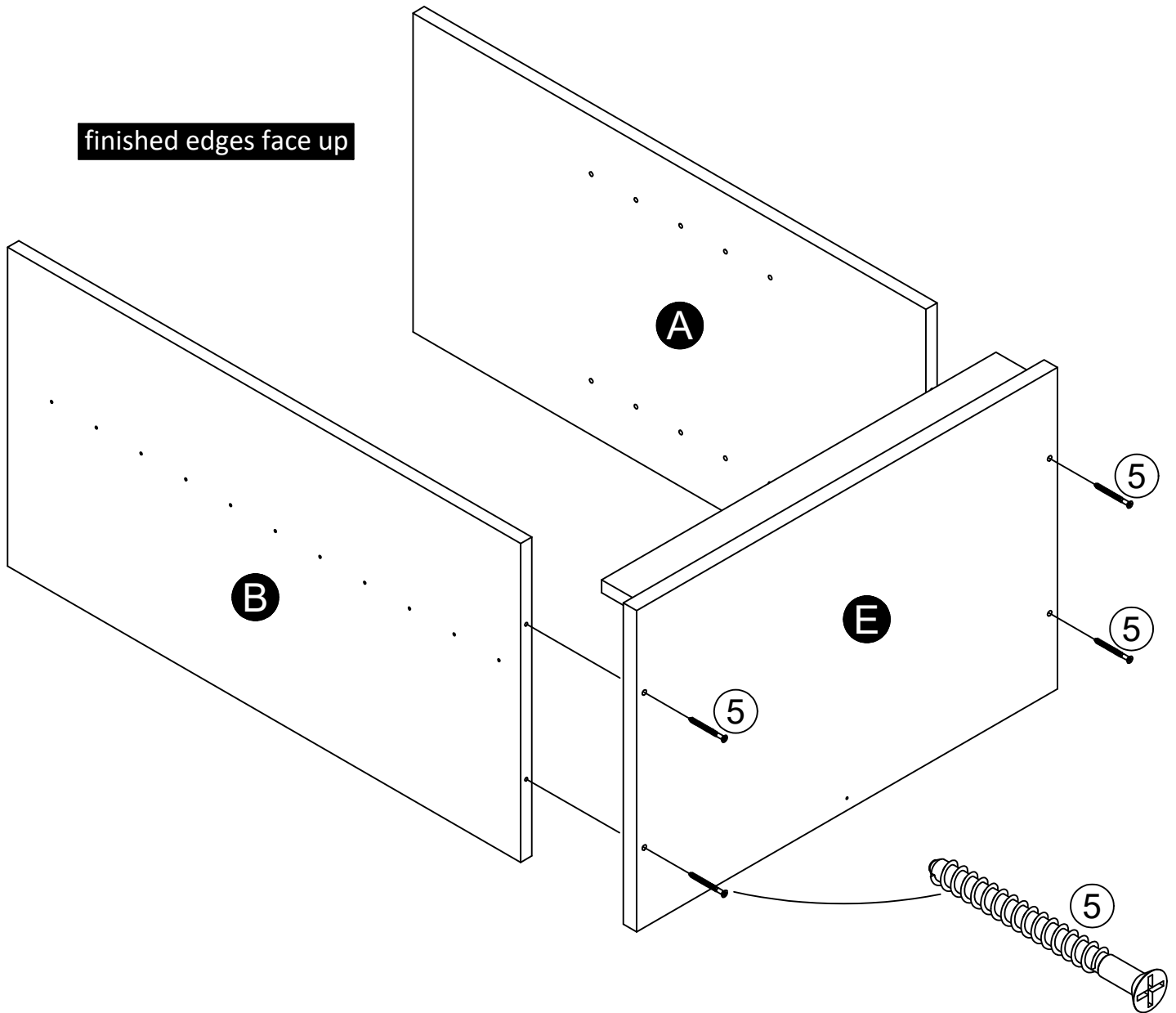

STEP 3

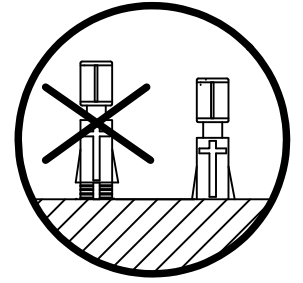
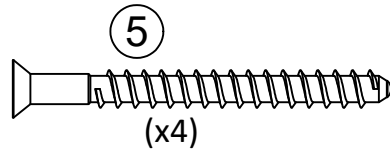
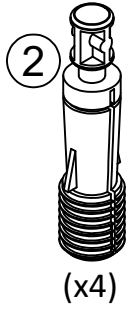
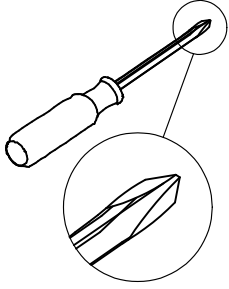

finished edges face up

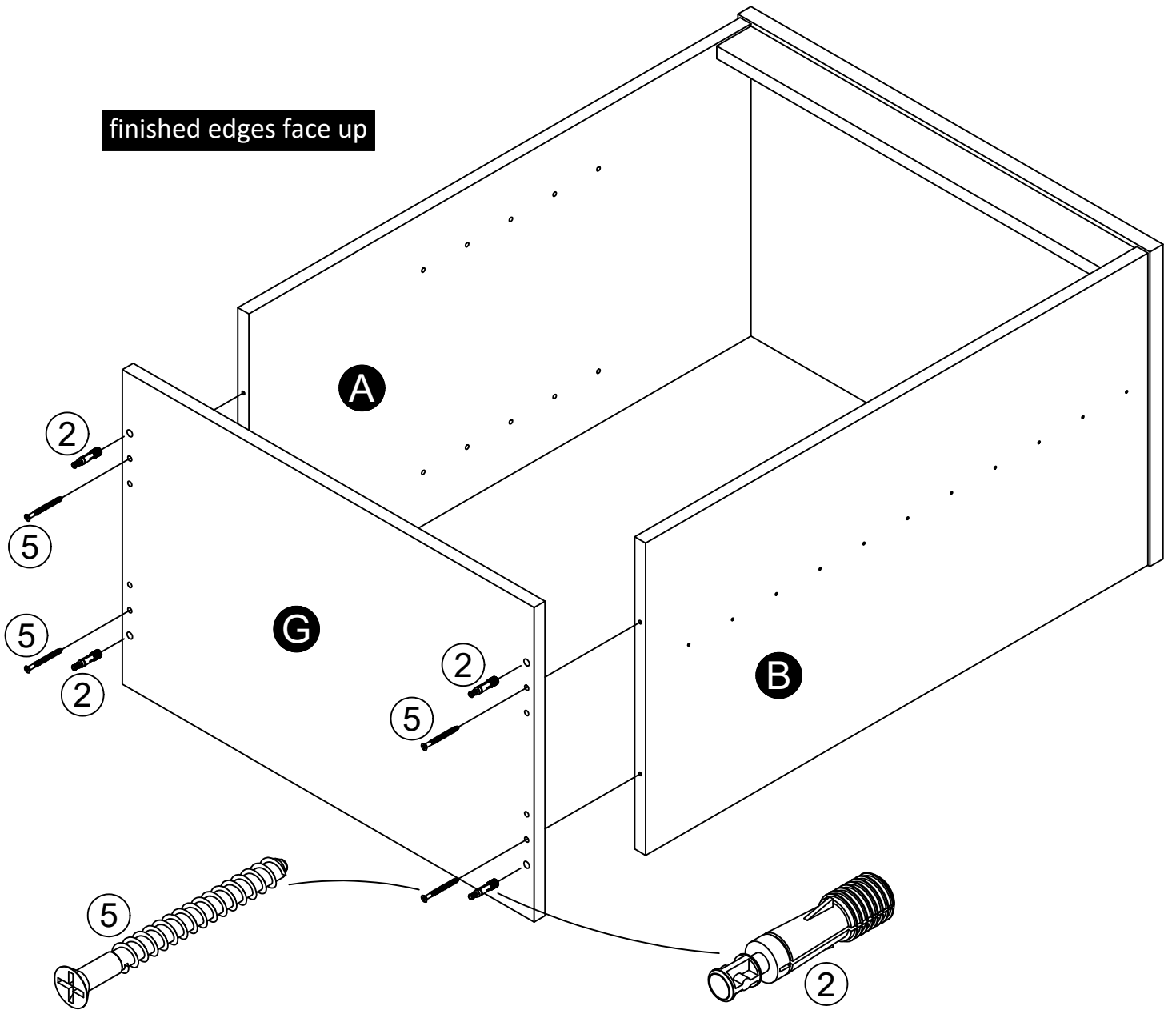

STEP 4

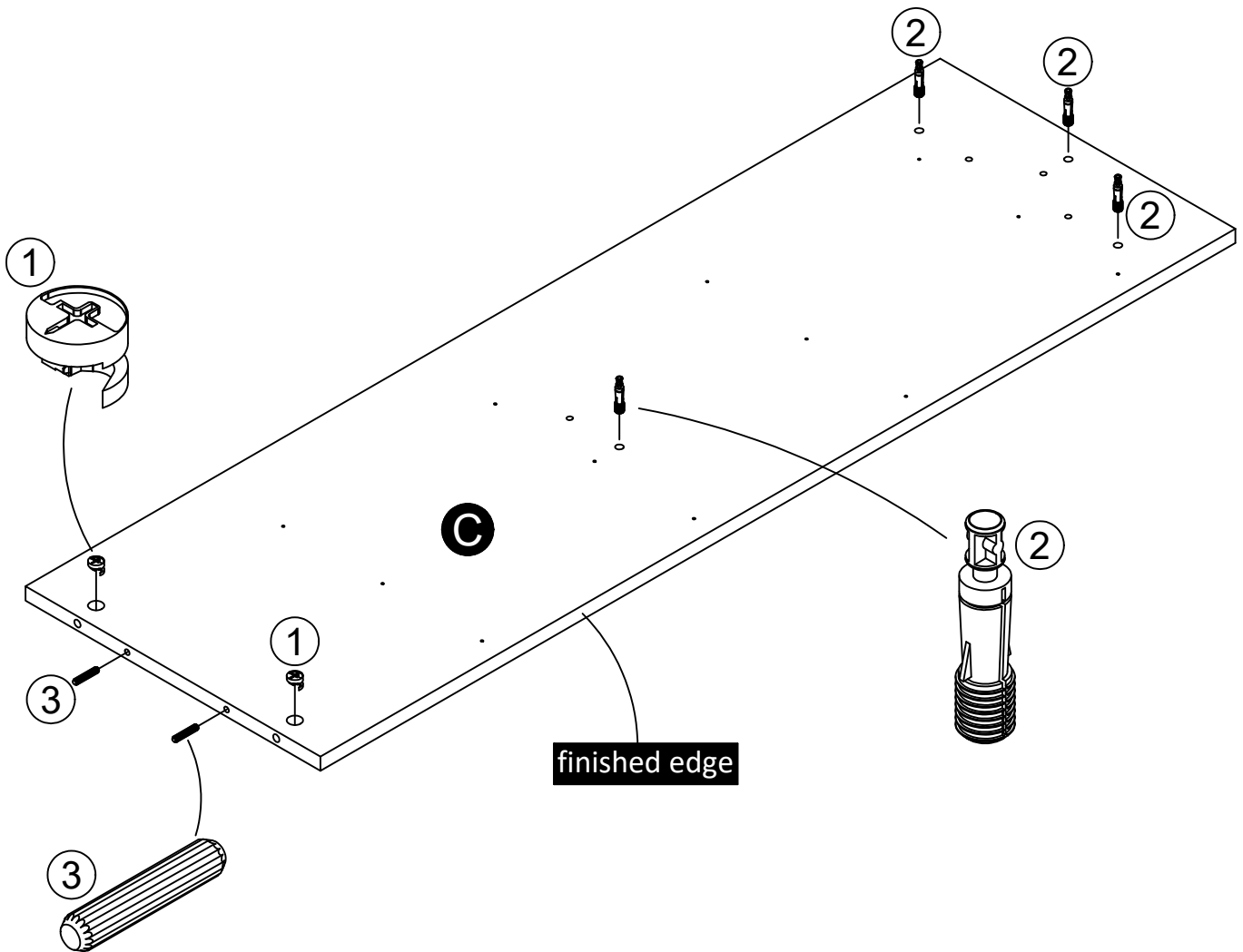
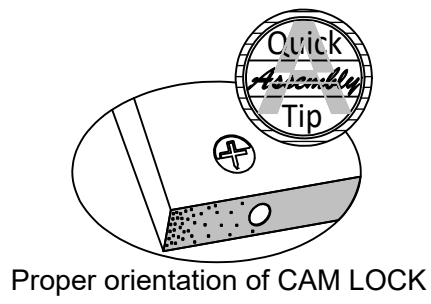
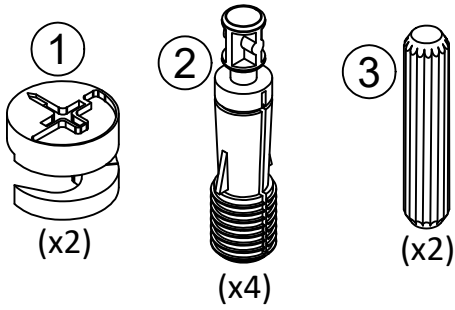

STEP 5

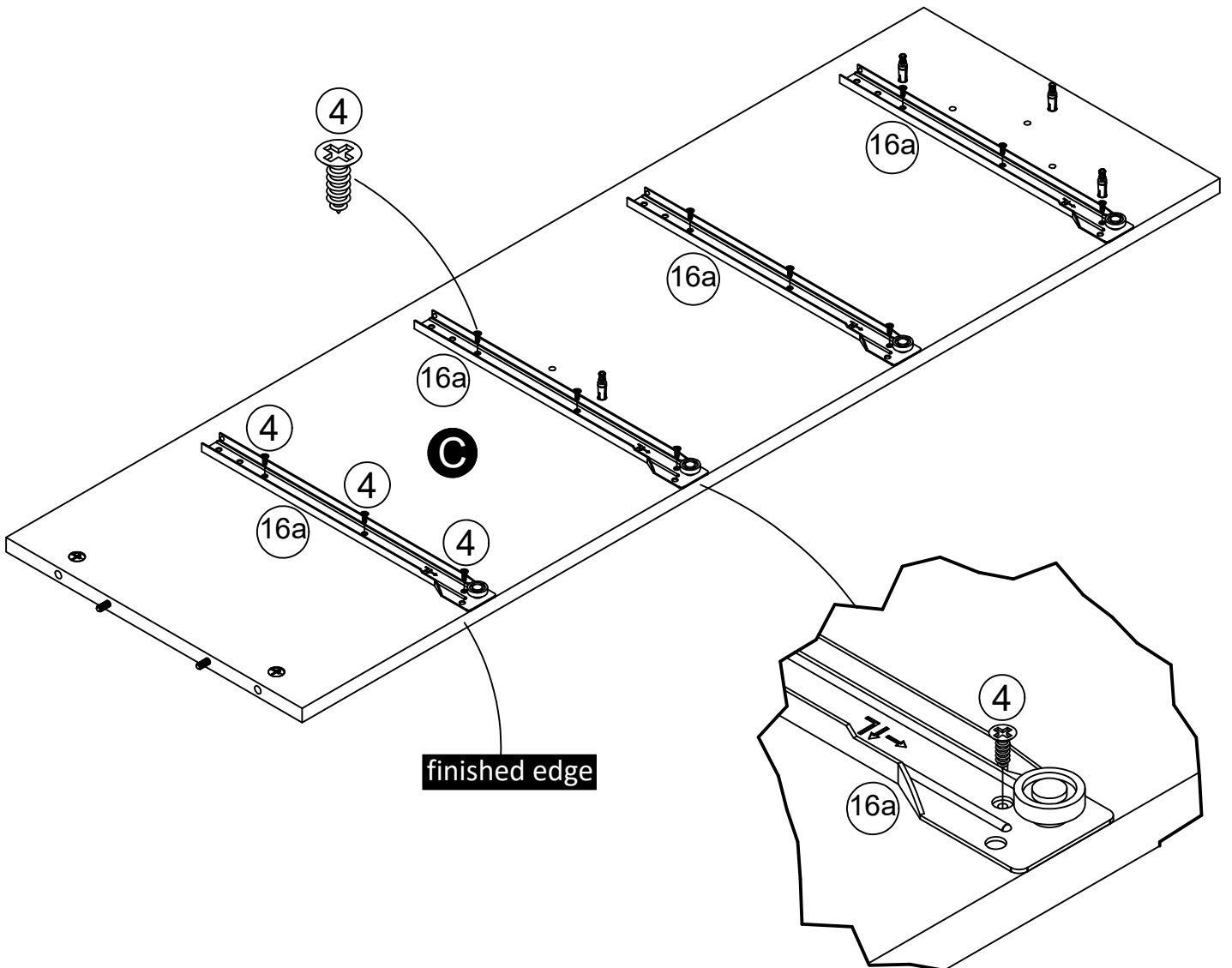
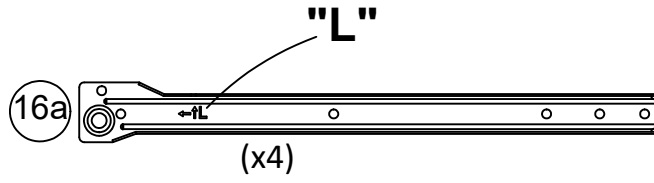
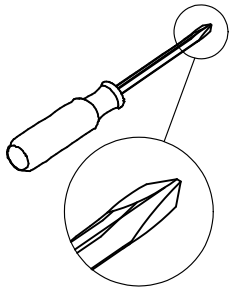

STEP 6

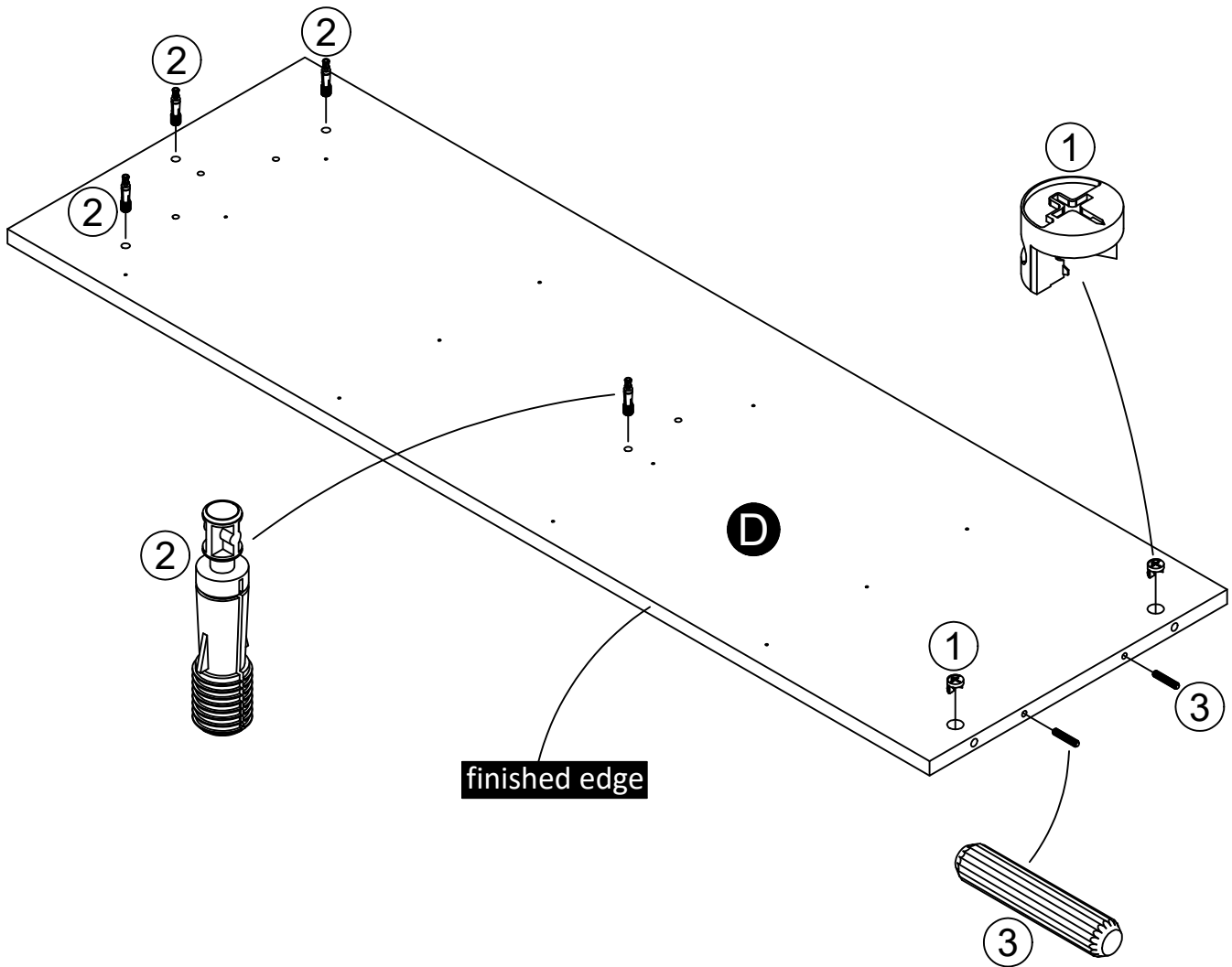
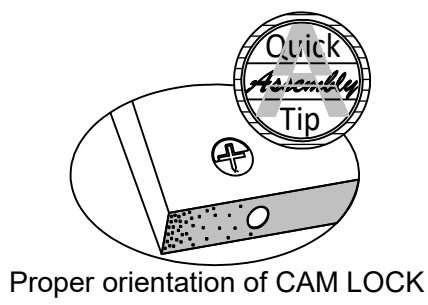
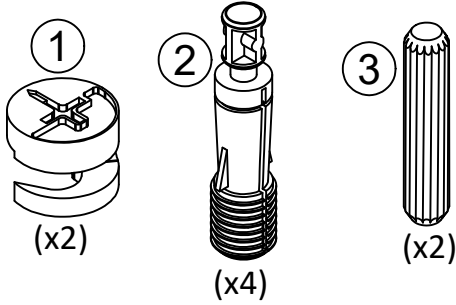

STEP 7

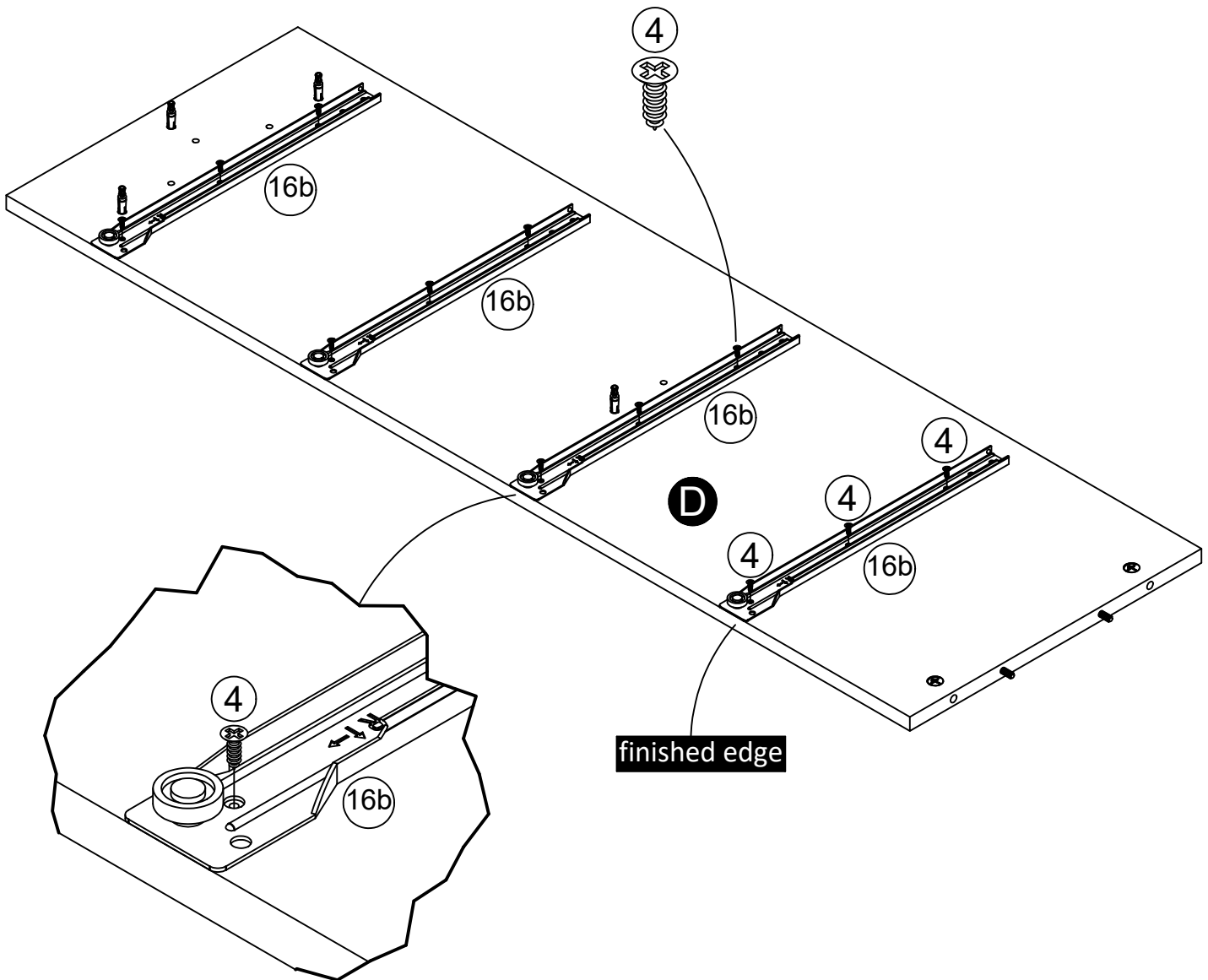
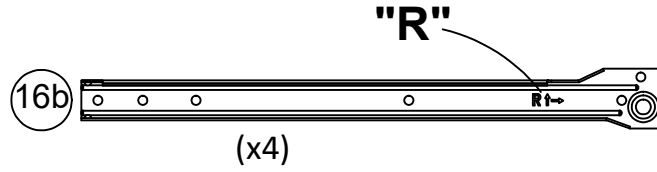
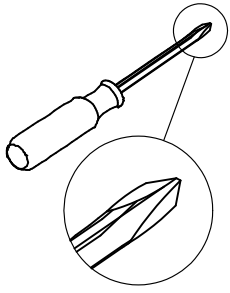

STEP 8

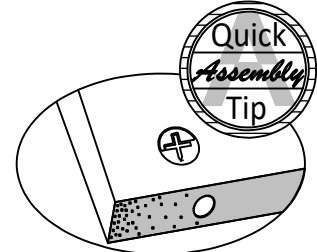
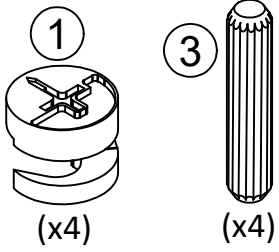

Proper orientation of CAM LOCK

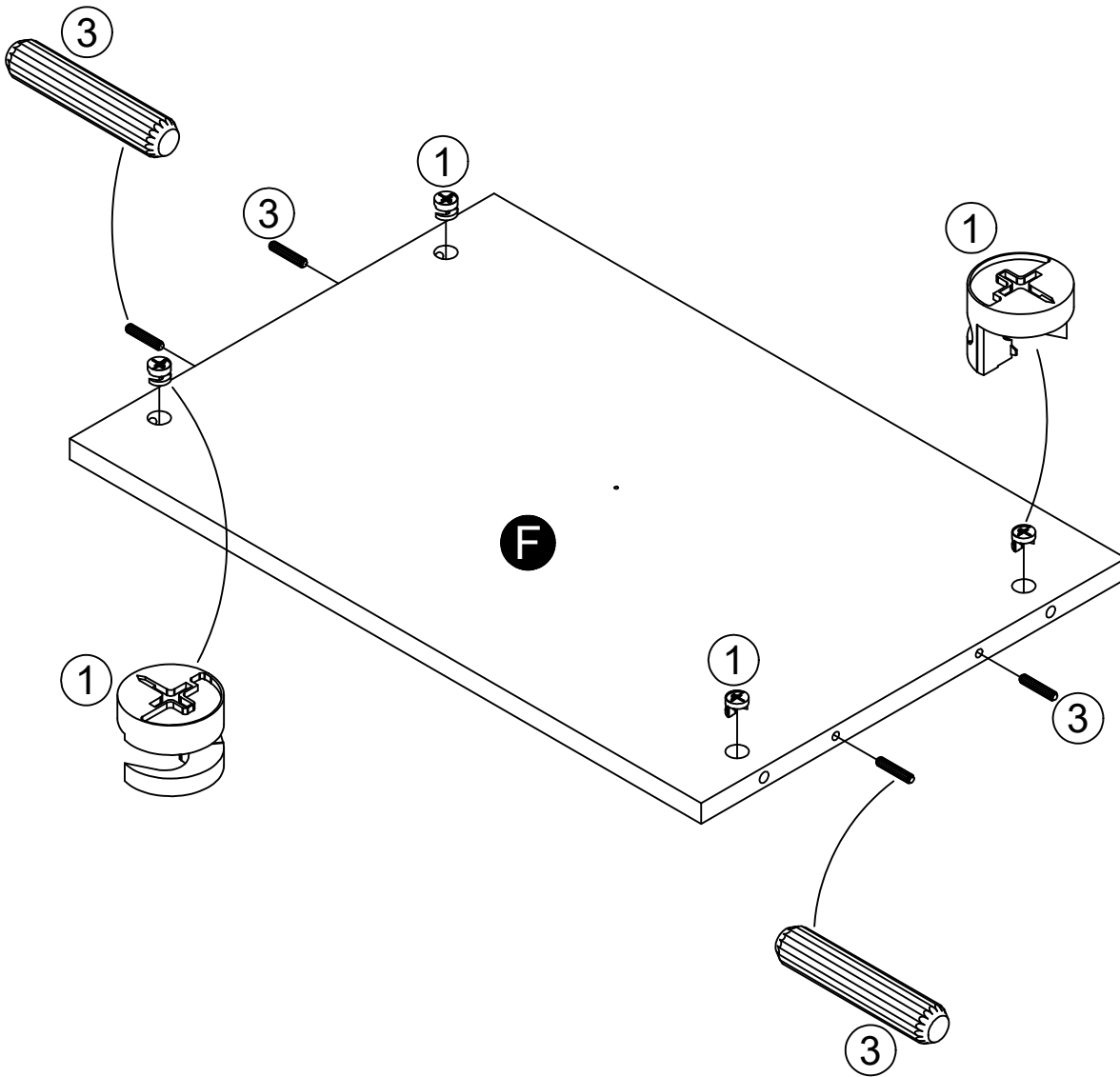

STEP 9

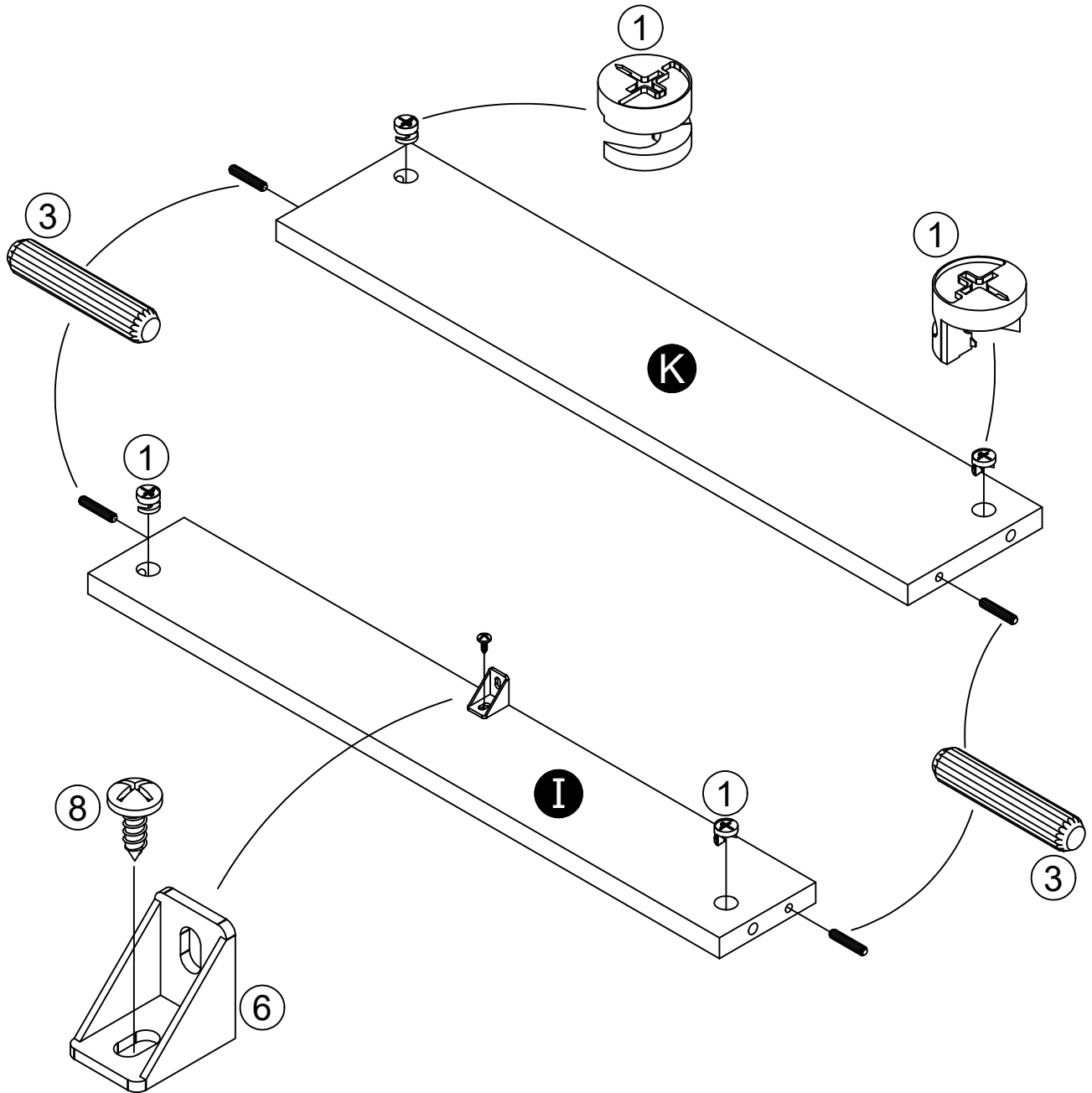
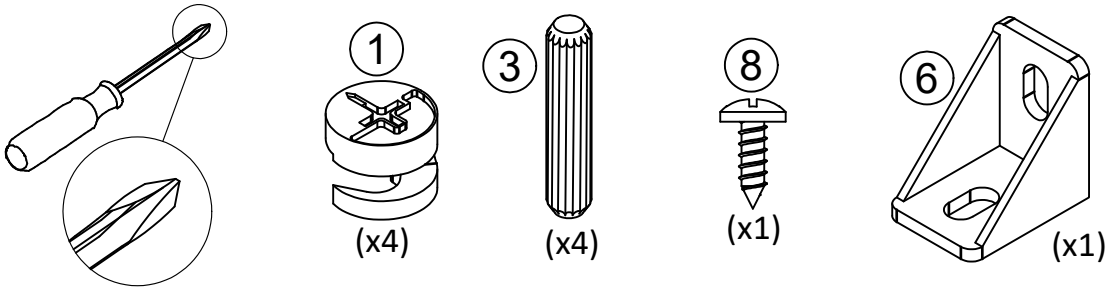

STEP 10

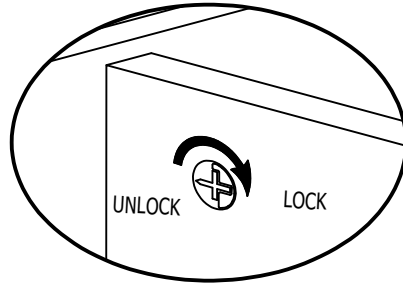
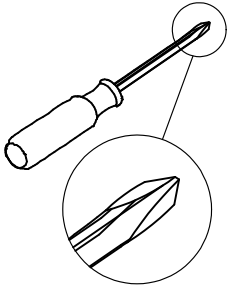

finished edges face up

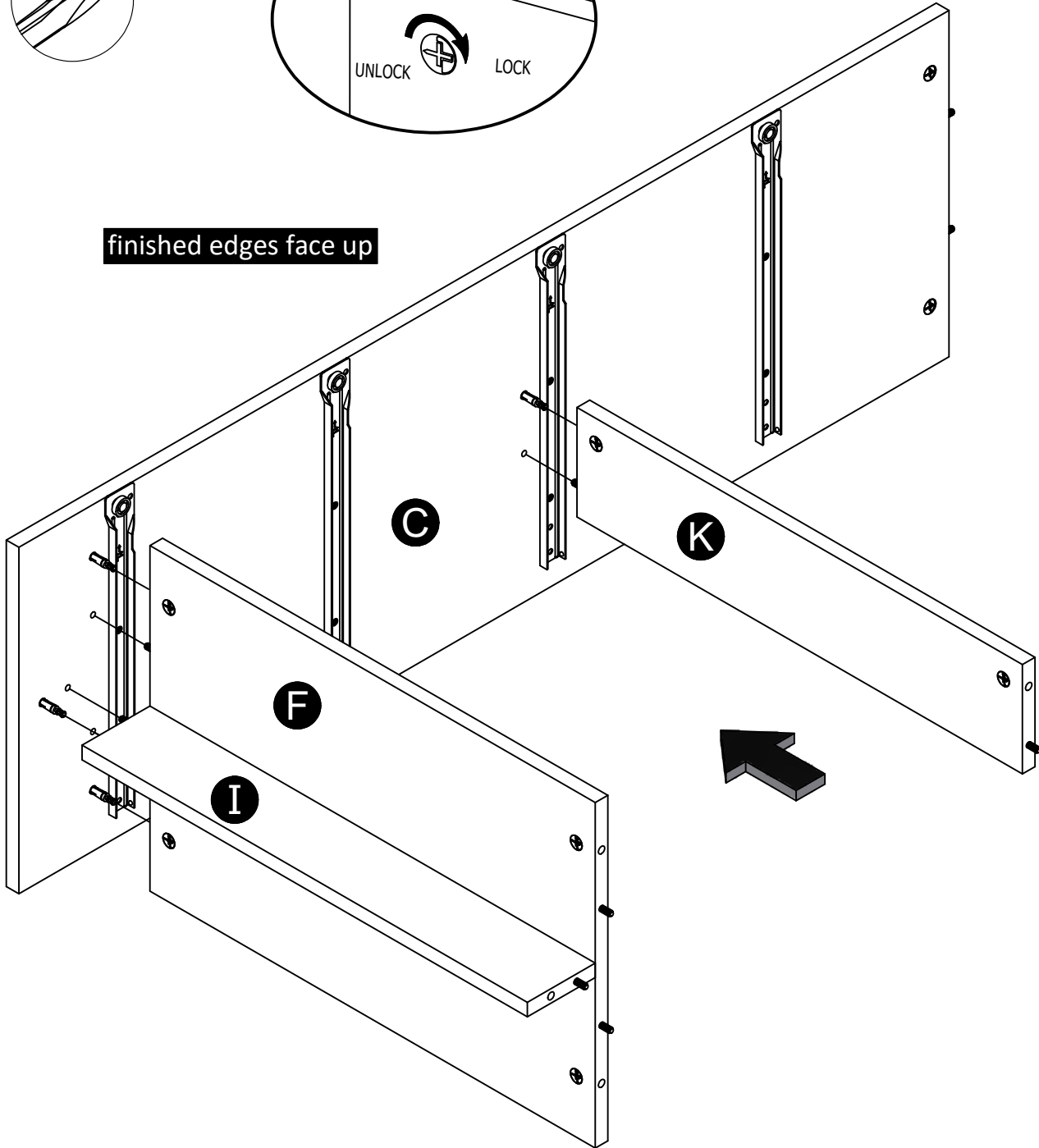

STEP 11

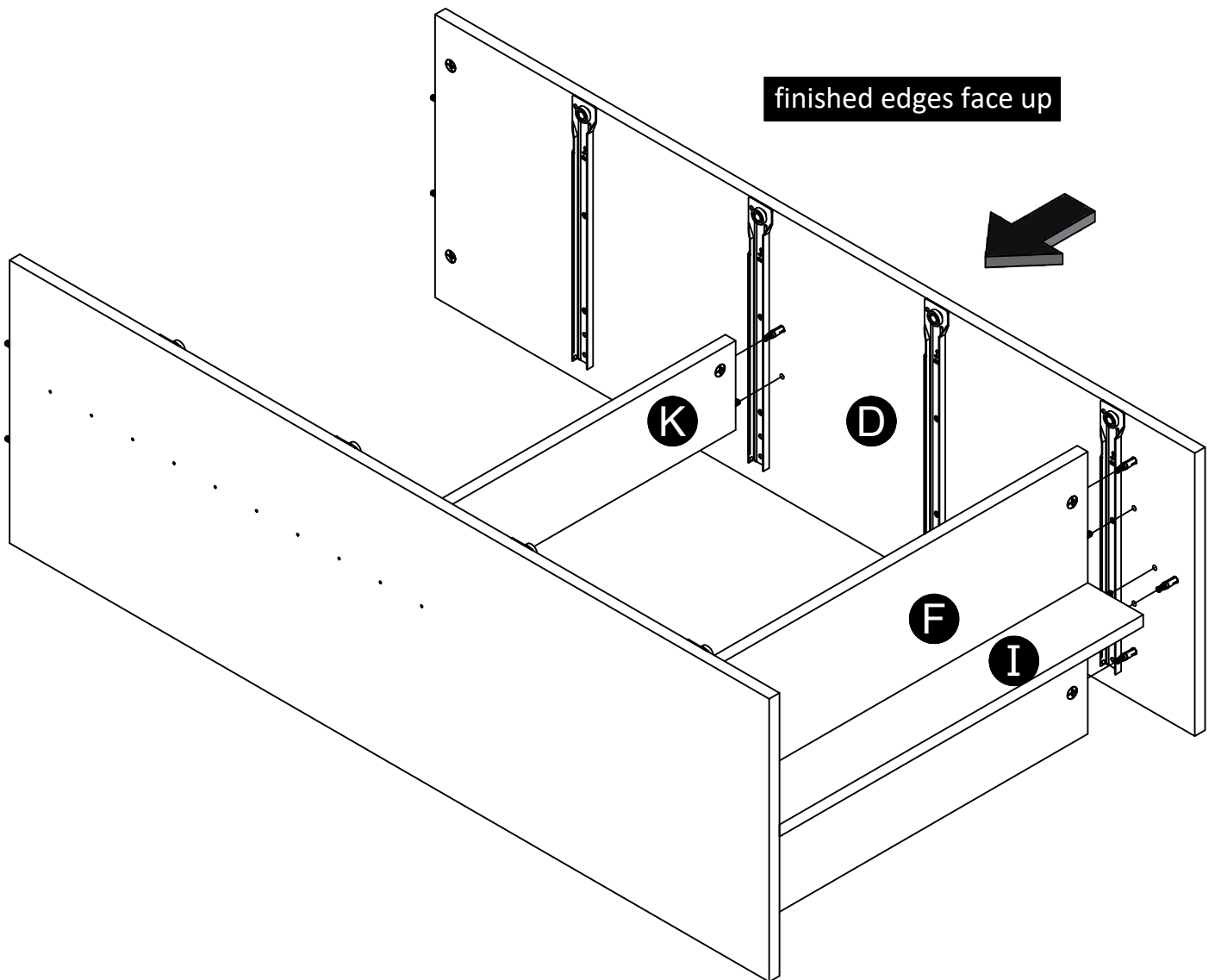
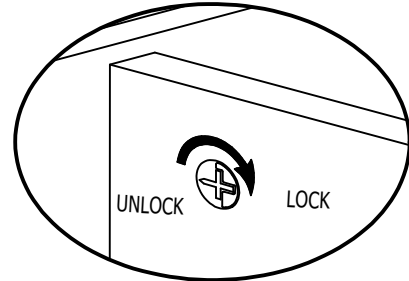
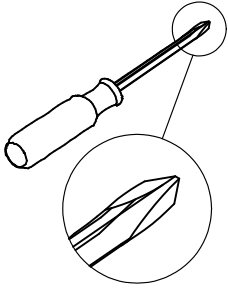

STEP 12

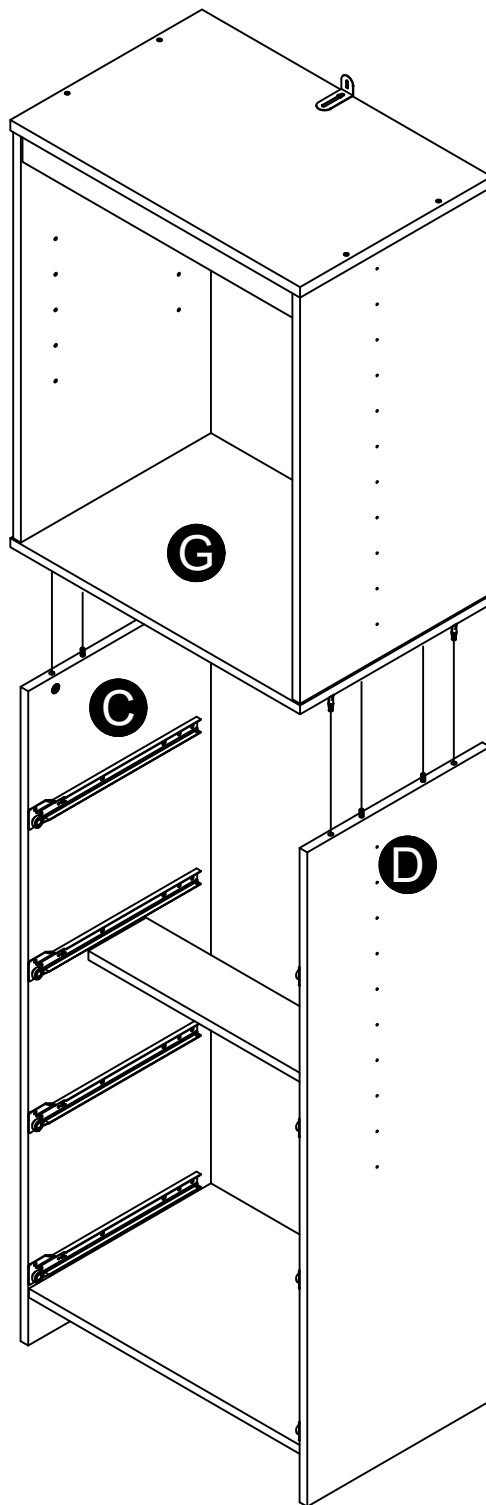
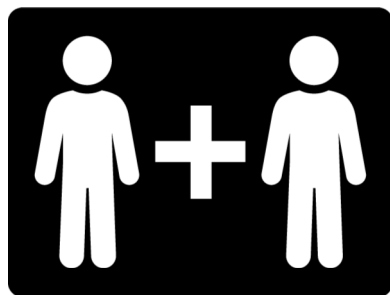
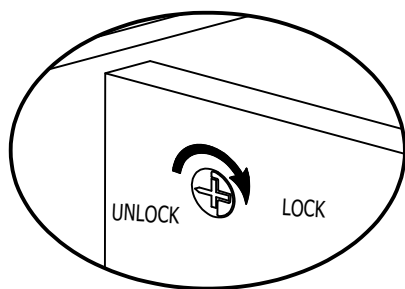
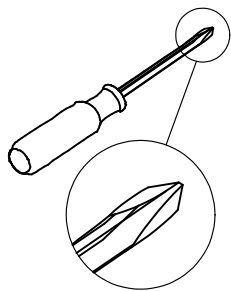

STEP 13

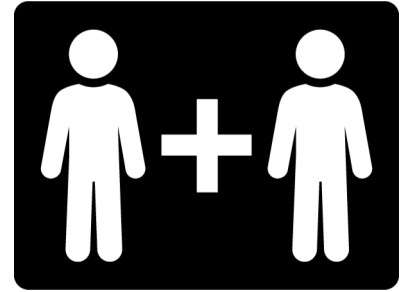
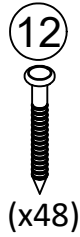
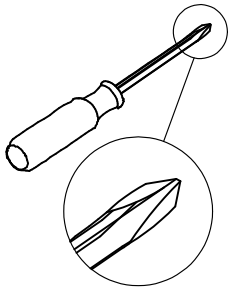

IMPORTANT! THE BACK PANELS ARE A STRUCTURAL PART OF THIS UNIT AND MUST BE INSTALLED PROPERLY.

Carefully turn your unit on its front side.

Attached the back panels as shown nailing straight into the raw edges.

IMPORTANT! Do not hammer in the nails in the center row until lower back panel is in place as the back panels will overlap.

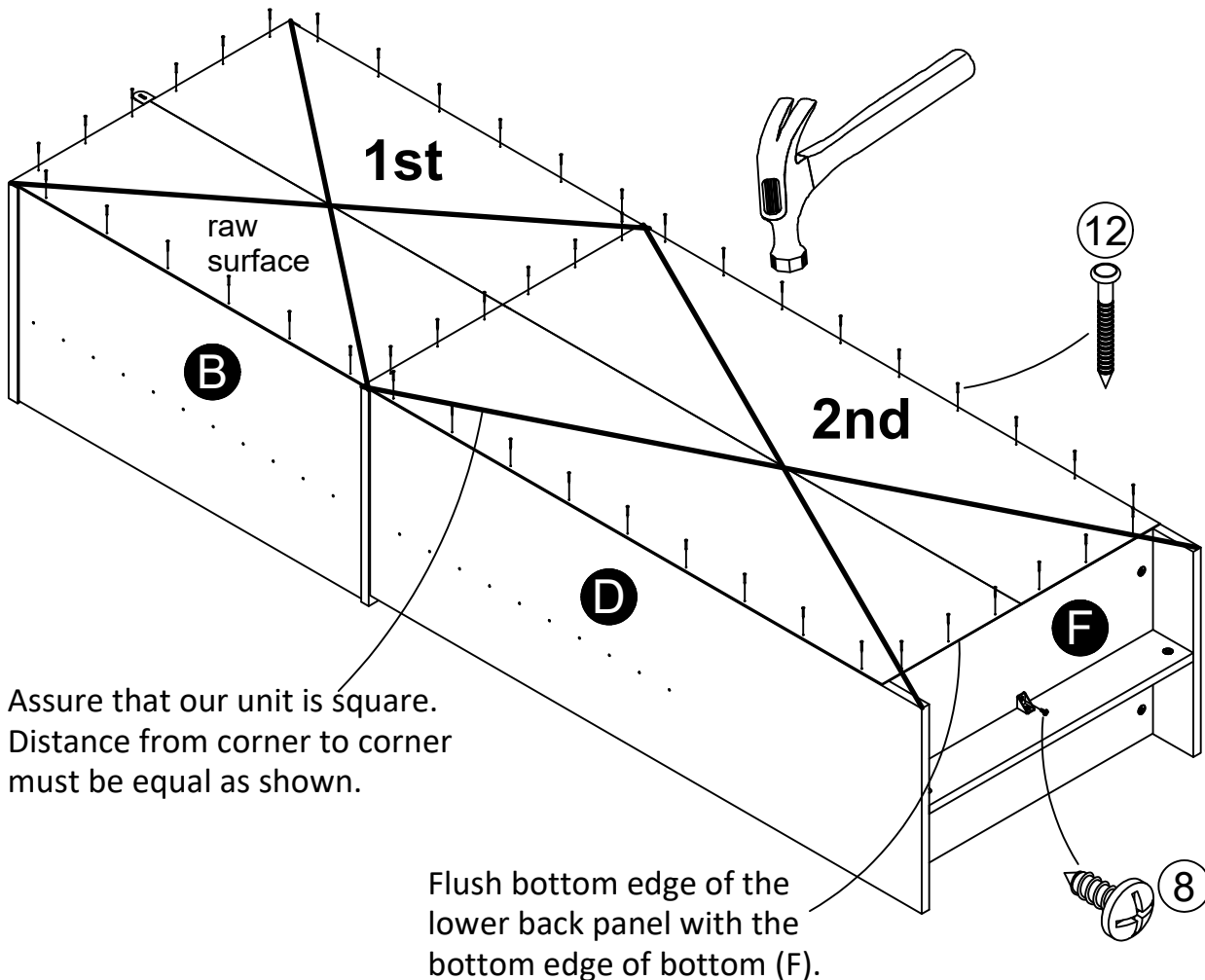

Assure that our unit is square.
Distance from corner to corner
must be equal as shown.

Flush bottom edge of the
lower back panel with the
bottom edge of bottom (F).

STEP 14

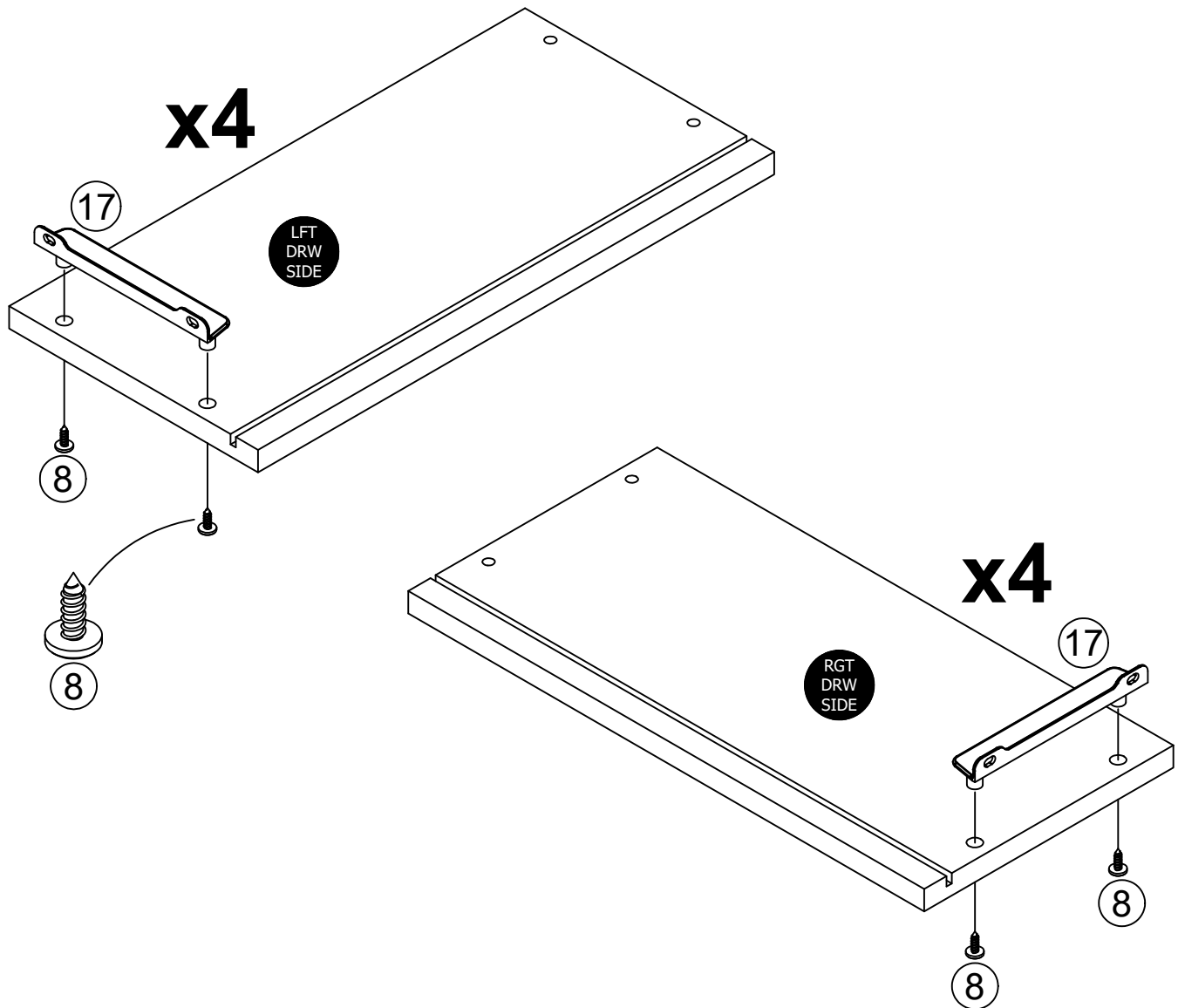
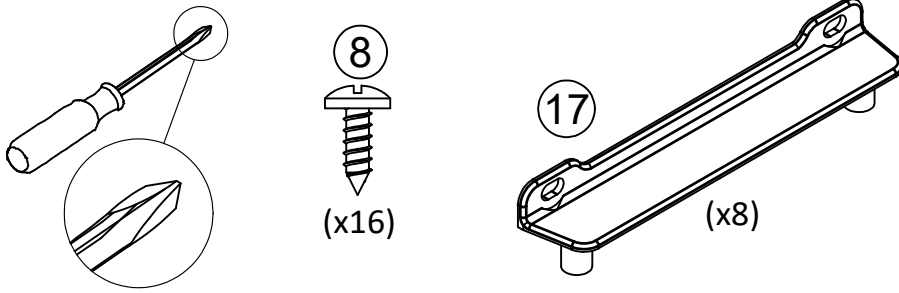

STEP 15

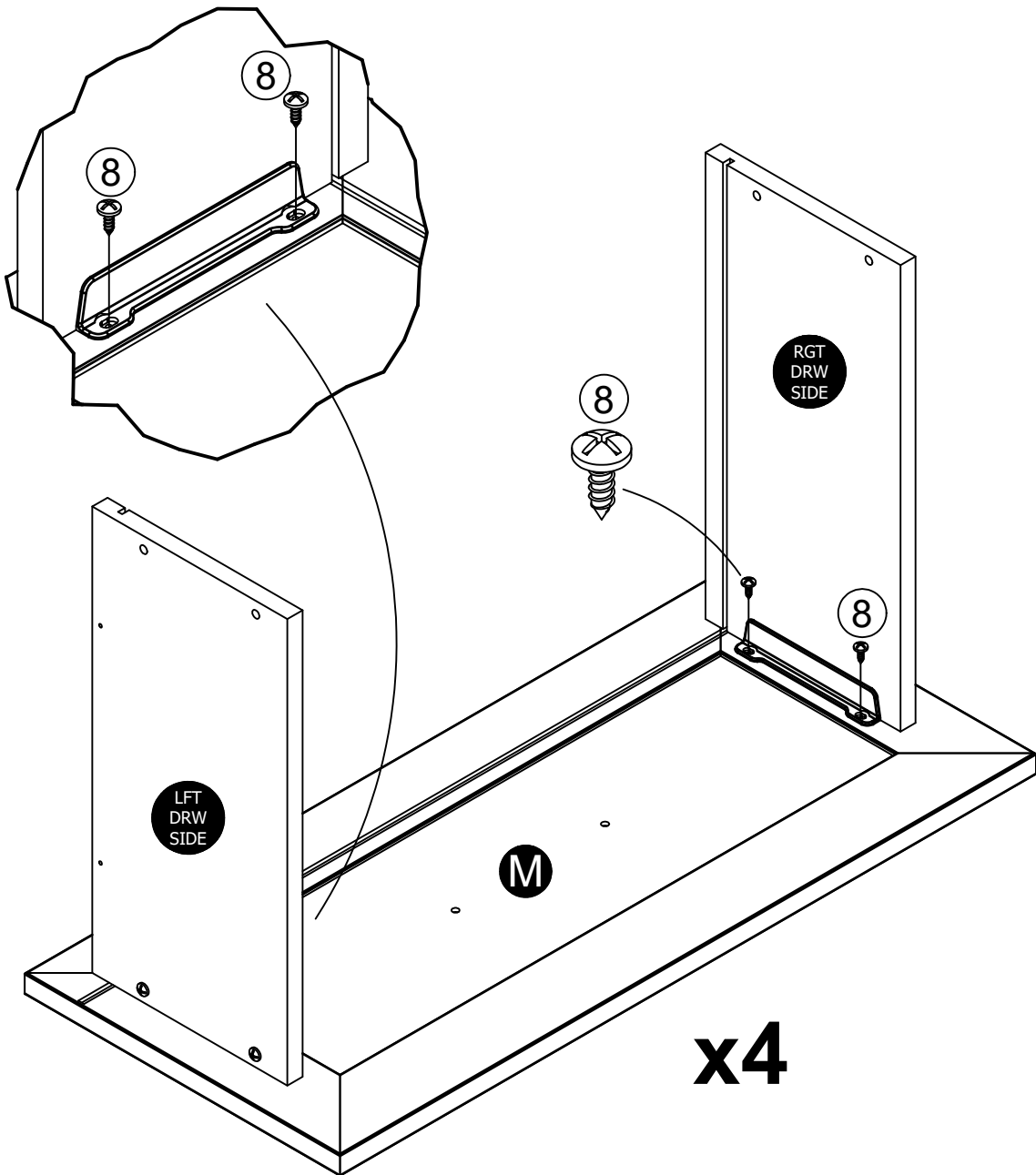
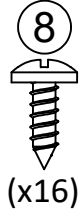
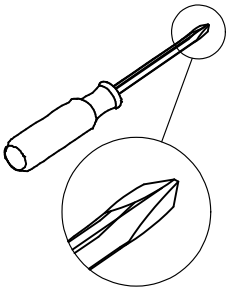

STEP 16

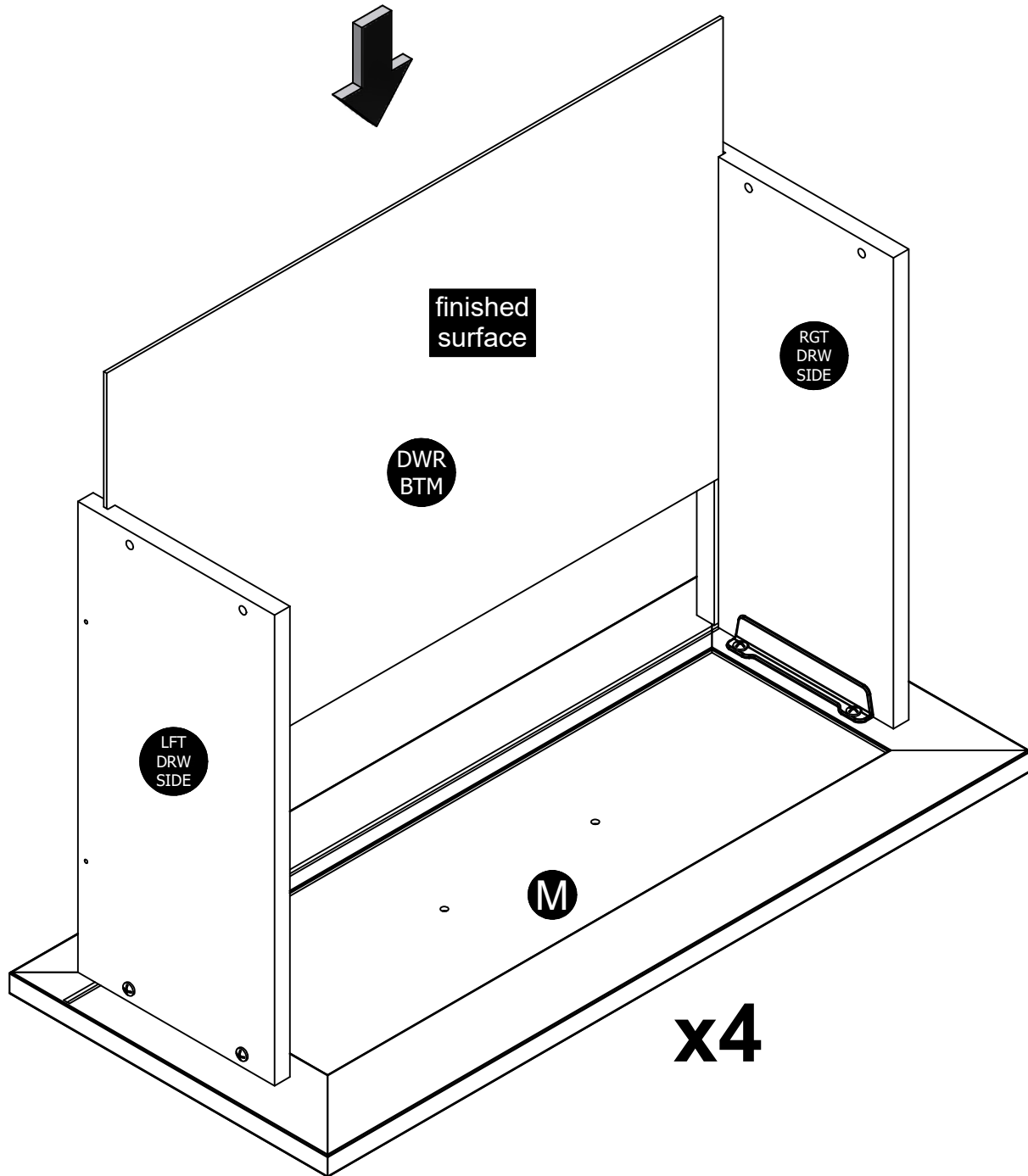

STEP 17

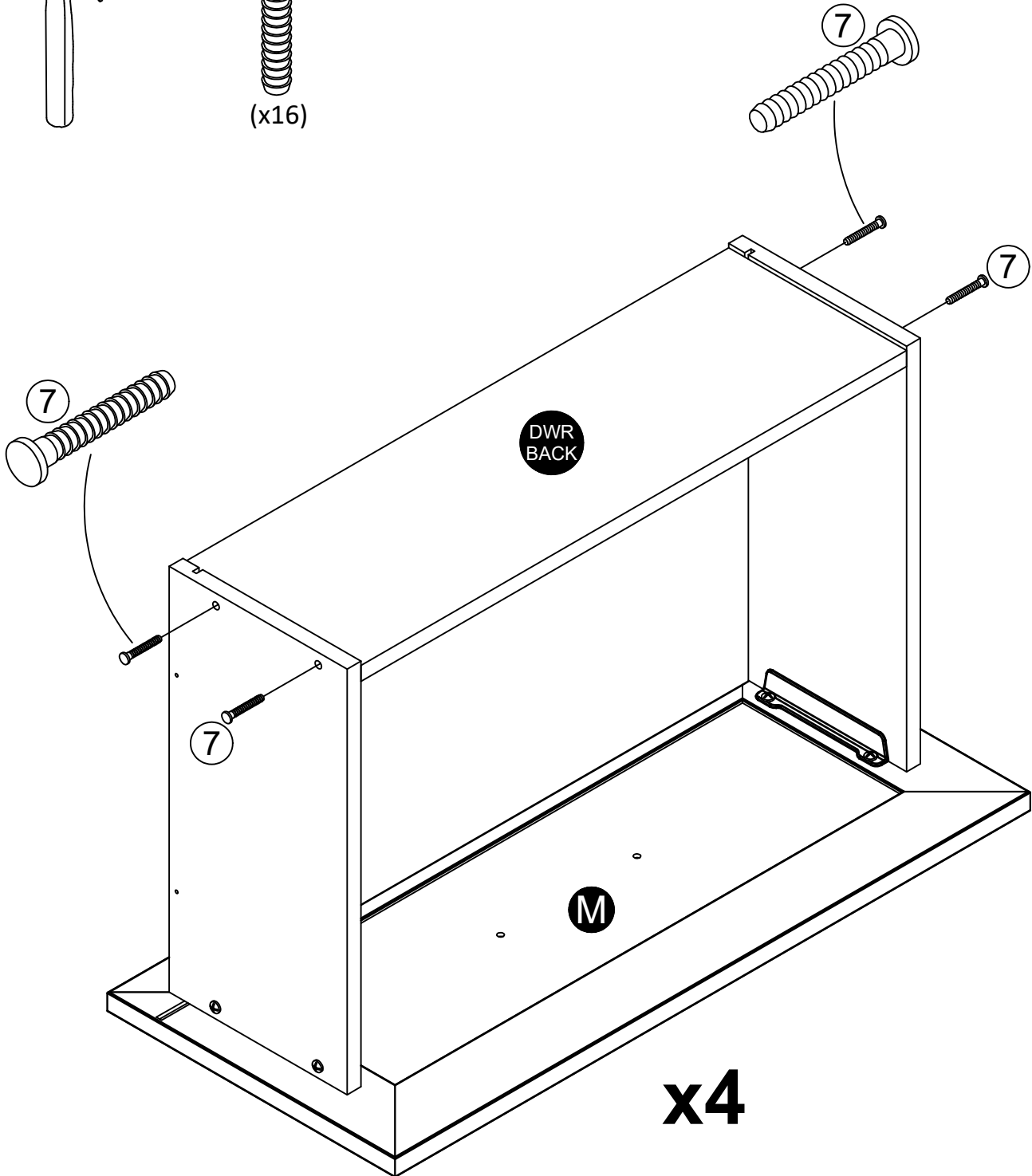
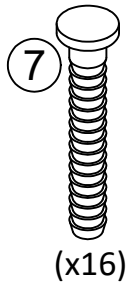
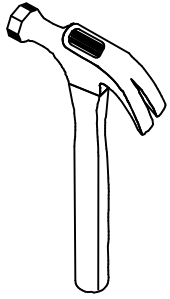

STEP 18

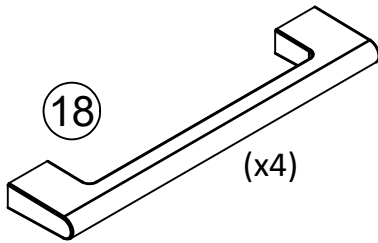
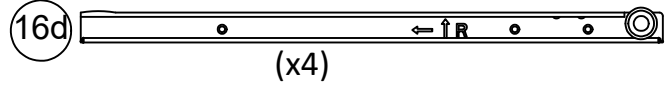
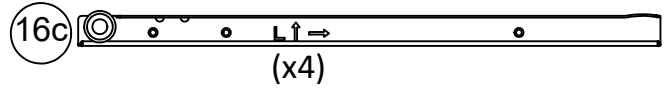
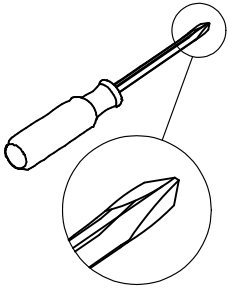

Attach the slides first
and then the handle.

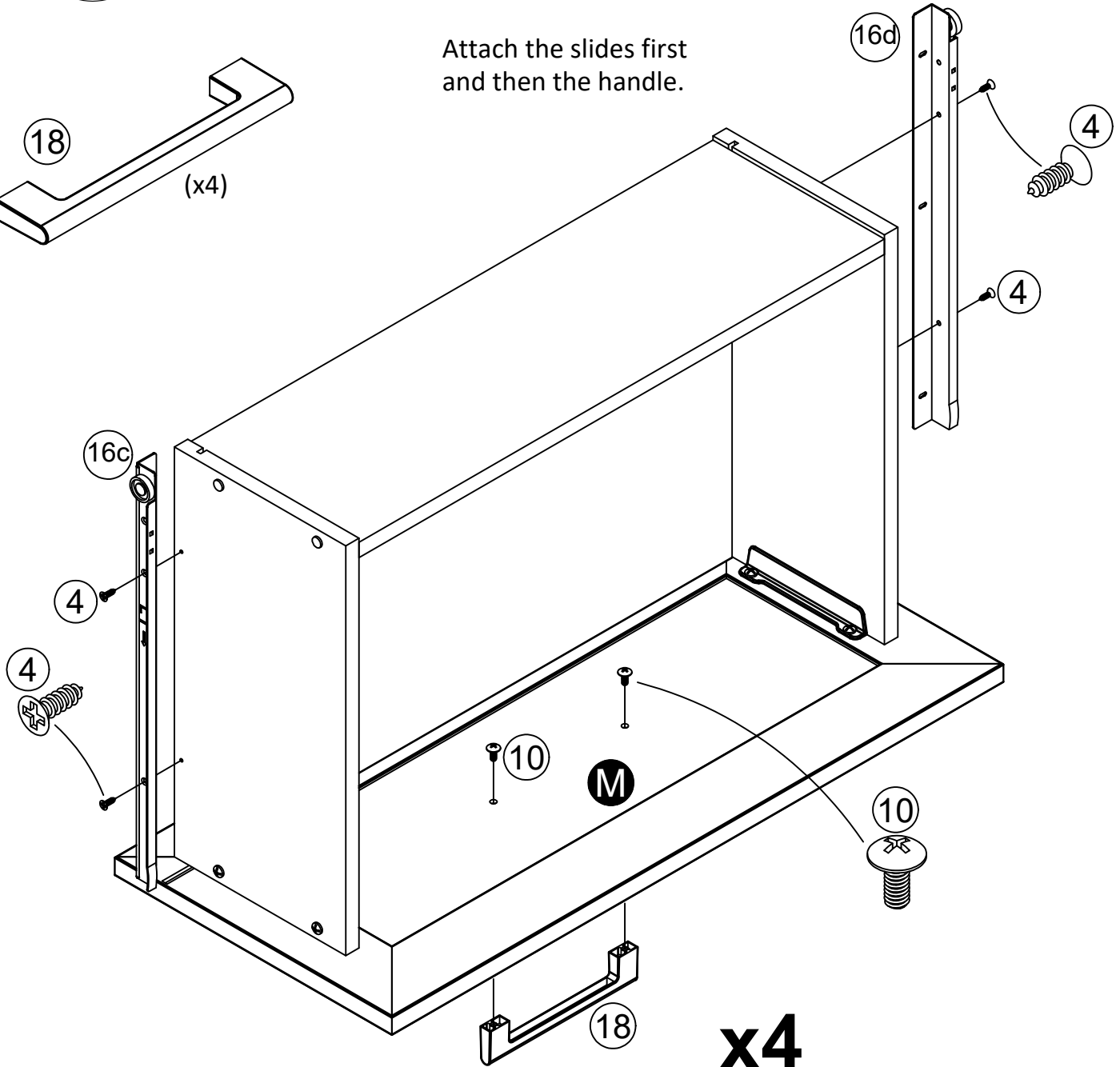

STEP 19

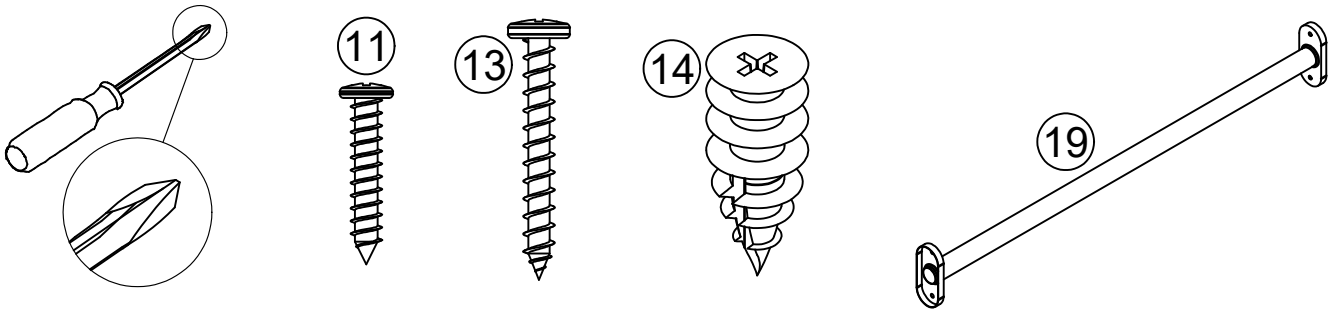

First, locate your rods where you would like to position them in-line with holes in the unit and mark hole locations on the wall. Next, if you are using the anchors to fasten the closet rods, insert them into the wall securely by screwing them into the wall using a screwdriver. Second, use the #A12700 screw to attach your closet rods to your unit as shown on the left side of the unit. Please note that the lower closet rod can go on either side of the unit. Next, attach the closet rods to the wall using the #A13020 screw.

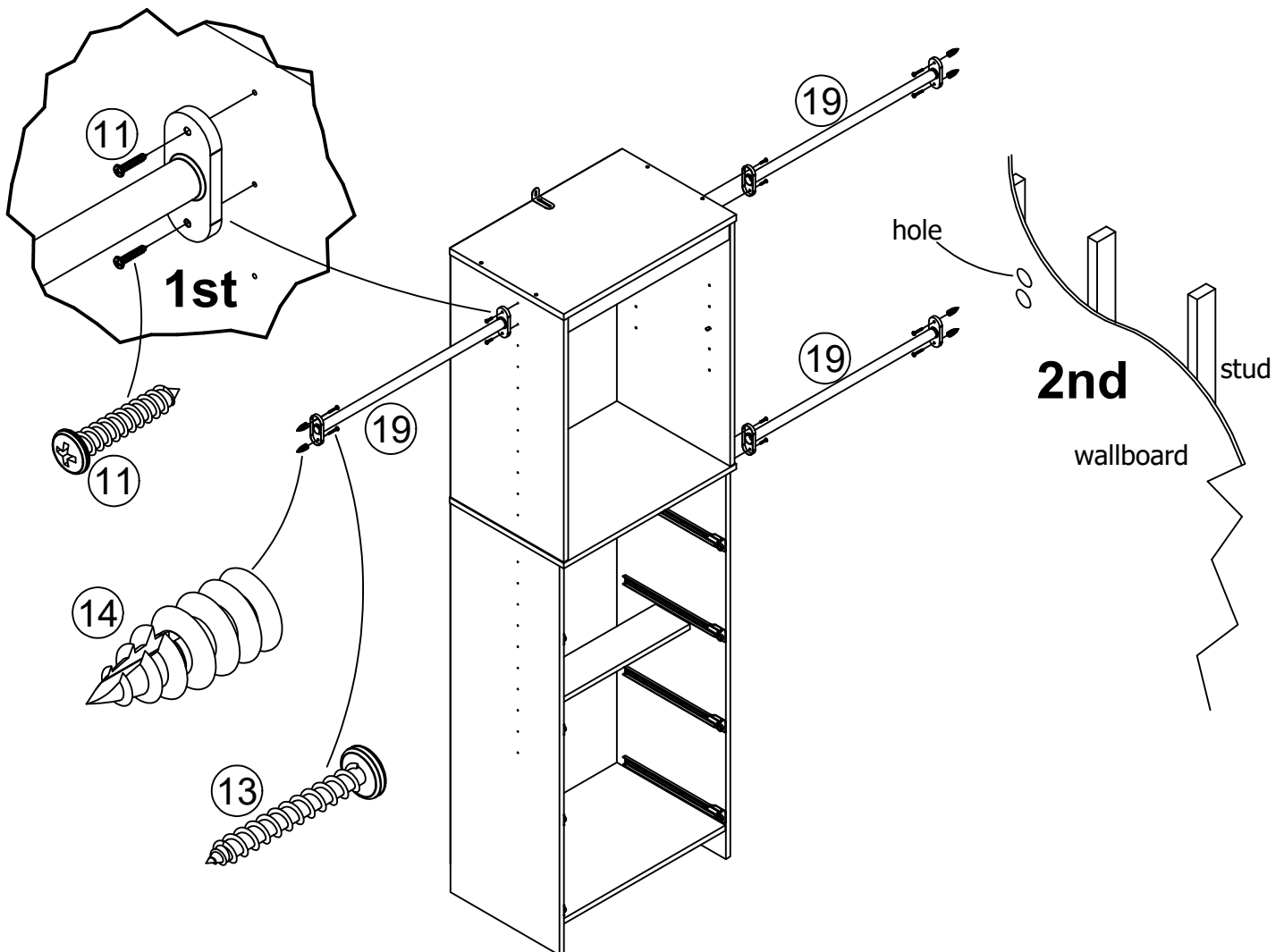

STEP 20

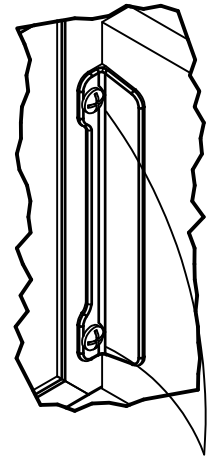
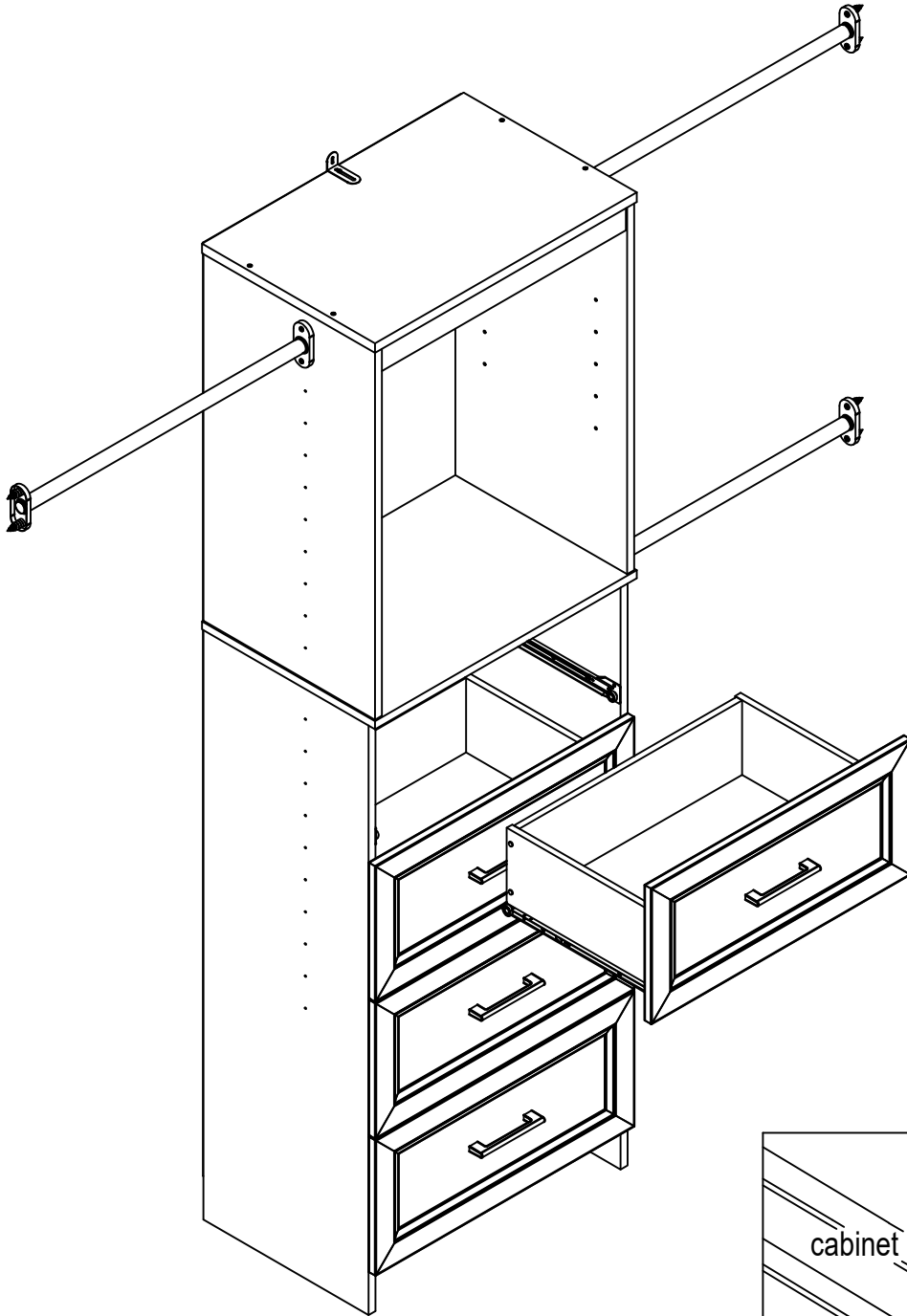

Note: The drawer bracket holes are slotted. Drawer fronts can be adjusted by loosening screws, making needed adjustments and retightening screws.

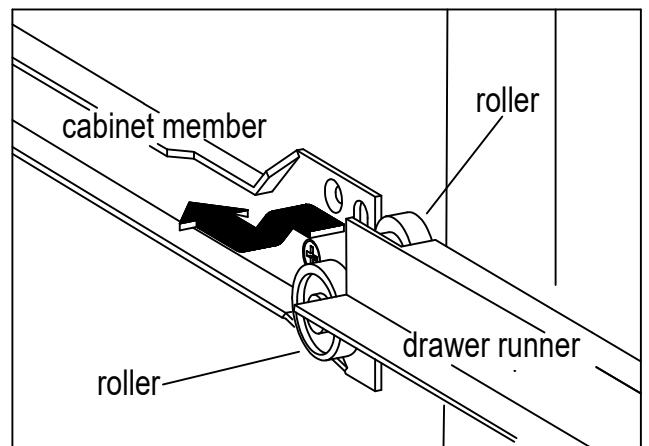

STEP 21

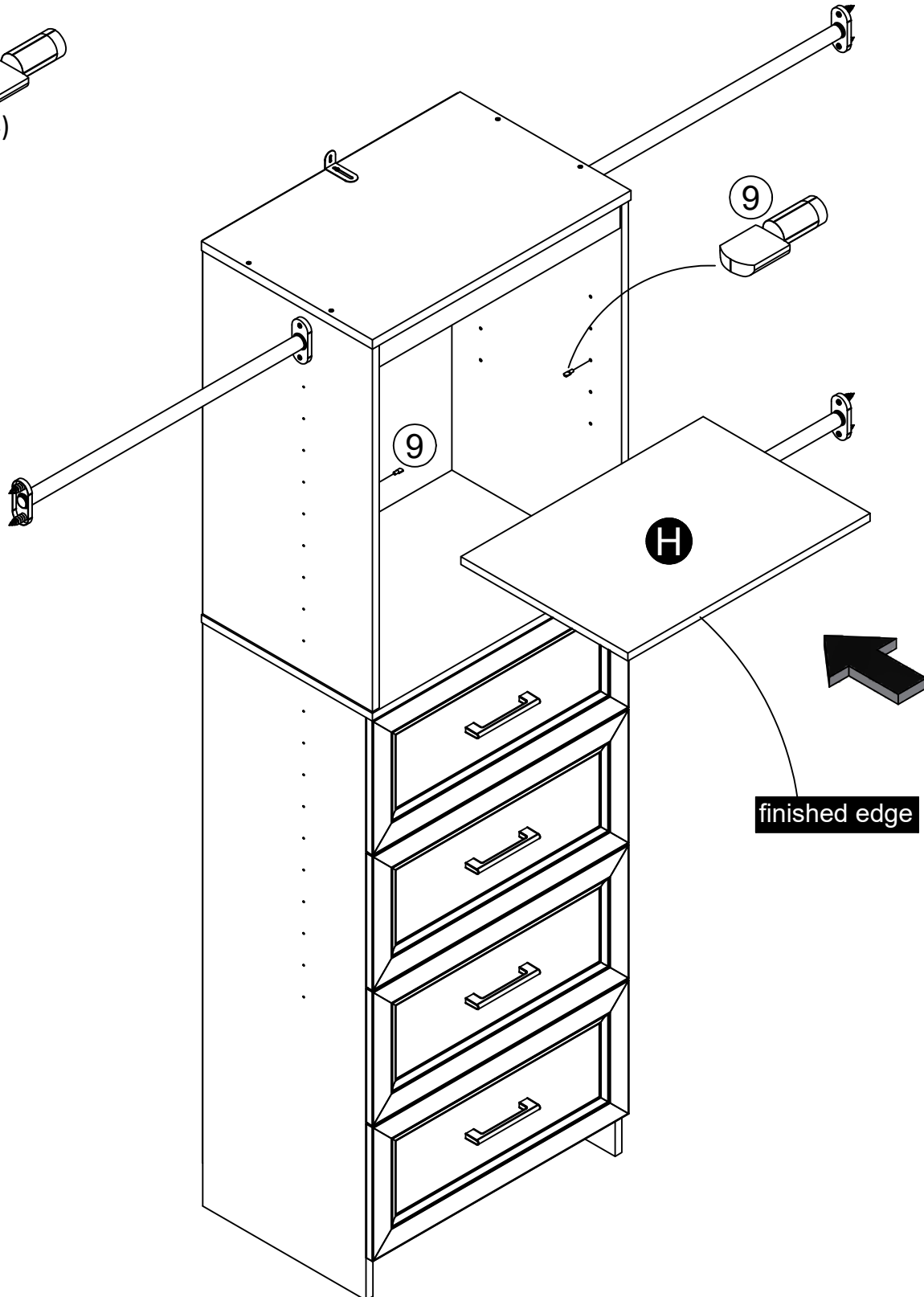
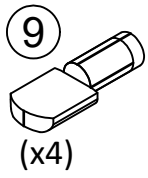

STEP 22

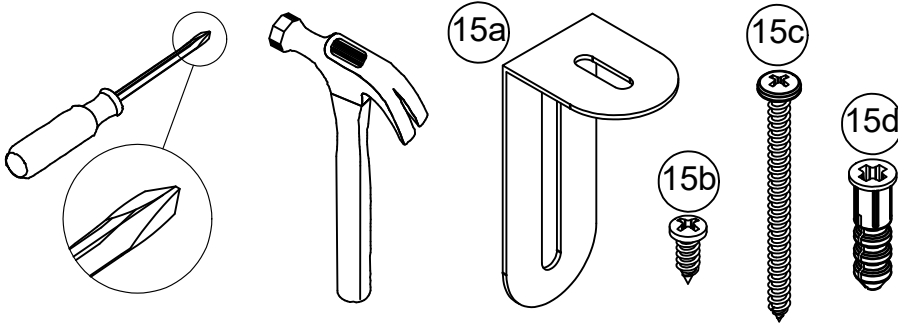

For Masonry, Concrete, or other wall materials:
Consult your local hardware store for appropriate anchors to securely attach the safety bracket.

IMPORTANT: THIS UNIT MUST BE SECURE TO THE WALL TO HELP PREVENT TIPOVER. FOLLOW THESE INSTRUCTIONS TO INSTALL THE ANTI-TIPPING SAFETY BRACKET PROVIDED WITH THIS PRODUCT.

WARNING
Serious or fatal crushing injuries can occur from furniture tipover.
To prevent tipover:

- * Install tipover restraint provided
- * Place heaviest items in the lowest drawers
- * Unless specifically designed to accommodate, do not set TVs or other heavy objects on the top of this product
- * Never allow children to climb or hang on drawers, door, or shelves
- * Never open more than one drawer at a time

Use of tipover restraints may only reduce, but not eliminate the risk of tipover

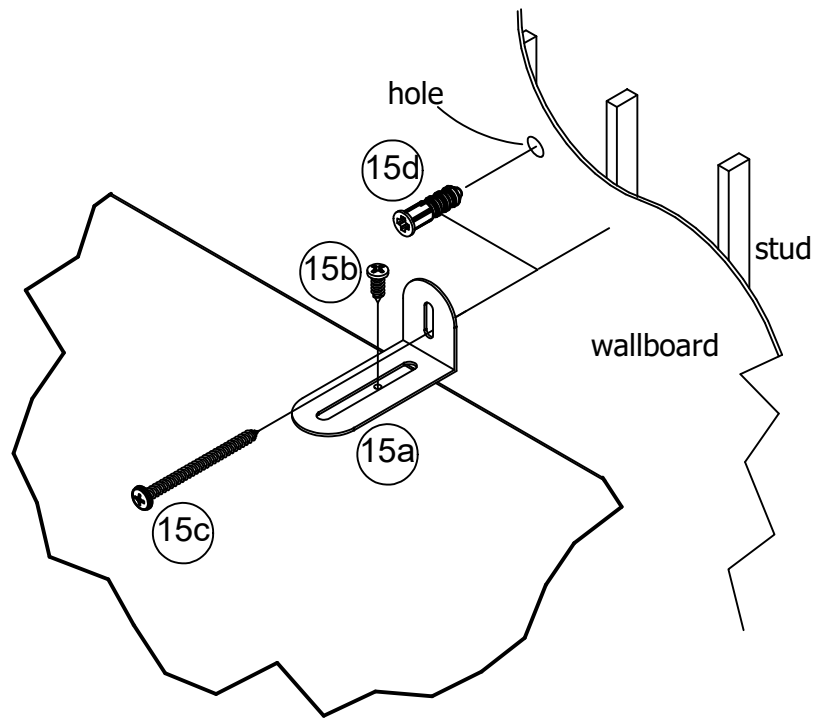

OPTION 1: Attachment into a wall stud (preferred method)

Using a stud finder, locate a stud in the wall. Place your unit against the wall, with the safety bracket aligned in this location. To make driving the screw easier, you can drill a 1/8" diameter pilot hole (3mm) through the safety bracket into the stud. Drive the screw through the safety bracket into the wall stud.

OPTION 2: Attachment into drywall

Locate your unit where desired against a wall and mark the wall through the safety bracket, then move your unit aside. Drill a 3/16" diameter hole (5mm) into the wallboard. Tap the wall anchor into the hole until it is flush. Move your unit into location and fasten the wall bracket to the wall anchor with the screw.

Maximum Loads

This unit has been designed to support the maximum loads shown. Exceeding these load limits could cause sagging, instability, product collapse, and/or serious injury.

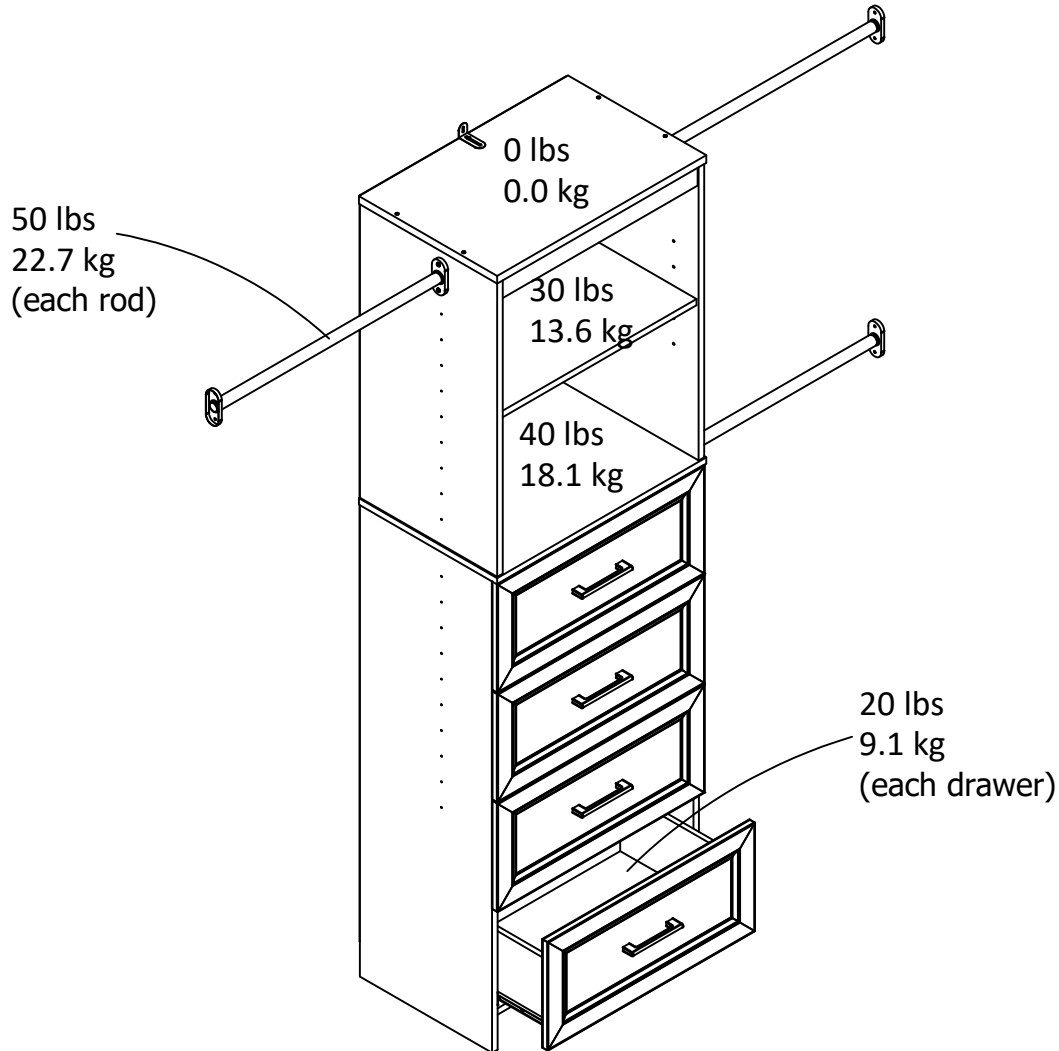

Warning: Risk of injury to persons - do not place a television on this furniture. This furniture is not approved for use with a television.

Certificate of Conformity

1. This certificate applies to the Dorel Home Furnishings, Inc. product identified by this instruction manual.
2. This certificate applies to compliance of this product with the CPSC Ban on Lead-Containing Paint (16 CFR 1303).
3. This product is distributed by: Dorel Home Furnishings, Inc.
410 East First Street South
Wright City, MO 63390
636-745-3351
4. Site of Manufacture: Tiffin OH
5. See front page of instruction manual for date of manufacture.

Register your product to receive the following:



- * New trend details - sneak peek on what's new
- * Surveys - have a voice within our community
- * Exclusive deals and discount codes
- * Quick and easy replacement part service

To register your product, visit systembuild.com

5 Star Rating



Visit your local retailer's website, rate your purchased product and leave us some feedback!

We would like to extend a big "Thank You" to all of our customers for taking the time to assemble this Systembuild product, and to give us your valuable feedback.

*Thank
You!*

Cubierta Delantera

Este libro de instrucciones contiene información **IMPORTANTE** de seguridad. Por favor lea y manténgalo para referencia en el futuro.

No Regrese este producto! Comuníquese con nuestro amigoso equipo de servicio al cliente para obtener ayuda.

Llámenos al: 1-866-452-4081 (Gratis) Lunes - Viernes 9am - 5pm CST

Visitar: www.systembuild.com

PRECAUCION

Este mueble puede volcarse y causar graves heridas y/o muerte.

Anclar el mueble a un poste de madera en la pared (si esto se requiere).

No Permita que los niños monten el mueble.

Mantenga los artículos más pesados en los cajones de abajo.

Consejos Útiles (página 2)

- Abra su artículo en el área donde usted planea utilizarlo para evitar levantar y moverlo menos
- Identificar, ordenar y contar las piezas antes de intentar ensamblar
- Las clavijas de compresión se golpean con un martillo
- Las diapositivas están marcadas con una R (derecha) y L (izquierda) para la colocación correcta
- Asegúrese de que siempre este el punto localizado en la parte superior de bloqueador de leva este volteado hacia borde exterior
- Utilizar todos los clavos para el panel de atrás y distribuirlos por igual
- El panel de atrás debe utilizarse para asegurarse de que la unidad quede fija y firme
- No use químicas fuertes ni limpiadores abrasivos en este artículo
- Nunca empuje, tire ni arrastre los muebles

Antes de Que Empieces (página 3)

- Lea cuidadosamente cada paso y siga el orden correcto
- Separar y contar todas sus piezas y hardware
- Dése suficiente espacio para el proceso de ensamble
- Tenga las siguientes herramientas: destornillador de cabeza plana, #2 cabeza Phillips
Destornillador y martillo
- Precaución: Si usa un taladro electrónico o un destornillador eléctrico para atornillar, por favor asegúrese que deje de atornillar cuando el tornillo este apretado. Fallar hacer esto puede causar barrer el tornillo.

Sistema de fijar el bloqueo de leva (página 3)

Esta sistema de fijar el bloqueo de leva sera usado en todo el proceso ensamble.

Página 21

¡ATENCIÓN! LOS PANELES POSTERIORES SON UNA PARTE ESTRUCTURAL DE ESTA UNIDAD Y DEBEN SER INSTALADOS CORRECTAMENTE.

Voltee con cuidado la unidad sobre su parte frontal.

Clave los paneles posteriores a los bordes con superficie sin tratar, tal como se muestra.

¡ATENCIÓN! No martille los clavos de la fila central hasta que el panel posterior inferior haya sido colocado, ya que los paneles posteriores quedarían superpuestos.

Asegúrese de que la unidad esté en ángulo recto.

La distancia de esquina a esquina debe ser igual a la que se muestra.

Haga coincidir el borde inferior del panel posterior inferior con el borde inferior que corresponde a la base (F).

Página 26

Coloque los rieles primero y luego la manija.

Página 27

Primero, sitúe las barras en el lugar donde desea colocarlas alineadas con los agujeros de la unidad y marque la posición de los agujeros en la pared. Luego, si va a utilizar los anclajes para fijar las barras del armario, insértelos en la pared atornillándolos firmemente. Después, utilice el tornillo #A12700 para fijar las barras del armario a la unidad como se muestra en el lado izquierdo de la misma. Tenga en cuenta que la barra inferior del armario se puede fijar a cualquier lado de la unidad. A continuación, fije las barras del armario a la pared con el tornillo #A13020.

Página 28

Nota: Los agujeros de anclaje del cajón están ranurados. El frente de los cajones se puede ajustar aflojando los tornillos, haciendo los ajustes necesarios y volviendo a apretar los tornillos.

Página 30

En cas mampostería, concreto u otros materiales de pared:

Pregunte en su ferretería local cuáles son los anclajes apropiados para fijar el soporte de seguridad con firmeza.

¡IMPORTANTE: ESTA UNIDAD SE DEBE FIJAR A LA PARED PARA EVITAR QUE SE VUELQUE. SIGA ESTAS INSTRUCCIONES PARA INSTALAR EL SOPORTE DE SEGURIDAD QUE SE INCLUYE CON EL PRODUCTO PARA PREVENIR CAÍDAS.

PRECAUCIÓN

La caída de muebles puede producir lesiones graves o incluso fatales.

Para evitar que se venga abajo:

- * Instale los accesorios de prevención de caídas incluidos
- * Coloque los objetos más pesados en los cajones de abajo
- * A menos que esté específicamente diseñado para ello, no coloque televisiones u otros objetos pesados en la parte superior de este producto

- * Nunca deje que los niños se suban o se cuelguen de los cajones, puertas o repisas
- * Nunca abra más de un cajón a la vez

El uso de accesorios de prevención de caídas puede solo reducir, mas no eliminar, el riesgo de que se vuelque

OPCIÓN 1: Fijación en una viga de la pared (método preferido)

Usando un detector de vigas, localice una viga en la pared. Coloque la unidad contra la pared con el soporte de seguridad alineado en esa ubicación. Para que resulte más sencillo atornillarla, puede perforar un agujero guía de 1/8" (3 mm) de diámetro a través del soporte de seguridad hacia la viga. Atornille en la viga de la pared a través del soporte de seguridad.

OPCIÓN 2: Fijación en paneles de yeso

Ubique su unidad donde la quiera colocar contra la pared y marque la pared a través del soporte de seguridad, luego haga la unidad a un lado. Perfore un agujero de 3/16" de diámetro (5 mm) en el panel de yeso. Golpee el anclaje de pared en el agujero hasta que quede al ras. Coloque la unidad en el lugar y fije el soporte de pared al anclaje con el tornillo.

Página 31

CARGA MAXIMA

Esta unidad fue diseñada para soportar las cargas máximas indicadas. Exceder dichos límites de carga podría provocar el hundimiento, la inestabilidad o la caída del producto y lesiones graves.

Advertencia: Riesgo de lesiones corporales - no ponga una televisión sobre este mueble. Este mueble no está diseñado para colocarle una televisión.

Página 32

Registre su producto para recibir lo siguiente:

- * Detalles de nuevas tendencias - Vistazo a lo nuevo
- * Encuestas - alec su voz entre su comunidad
- * Códigos de ofertas y descuentos exclusivos
- * Fácil y rápido servicio de partes de remplace

Para registrar su producto, visite systembuild.com

Clasificación de 5 estrellas

Visite el sitio web de su tienda local, califique su comprado y denos sus comentarios!

Nos gustaría enviar un gran "Agradecimiento" a todos nuestros clientes por tomarse el tiempo de ensamblar este producto de Systembuild, y por darnos sus valiosos comentarios.

Gracias

Couverture Avant

CE LIVRET D'INSTRUCTION CONTIENT DES INFORMATIONS **IMPORTANTES** SUR LA SÉCURITÉ. VEUILLEZ LIRE ET GARDER POUR UNE RÉFÉRENCE FUTURE

Ne retournez pas ce produit! Contactez notre équipe de service à la clientèle amicale d'abord pour obtenir de l'aide.

Appelez-nous: 1-866-452-4081 (sans frais) du Lundi au Vendredi de 9h à 17h Heure Centrale

Visitez: www.systembuild.com

ATTENTION

Le meuble peut basculer et causer des blessures graves ou la mort.

Ancrer le meuble à une planche murale dans le mur (si indiqué).

Ne laissez pas les enfants grimper sur le meuble.

Placez les articles lourds sur les étagères ou dans les tiroirs inférieurs.

Astuces Utiles (page 2)

-Ouvrez votre article dans la zone que vous prévoyez de le garder pour moins de levage lourd

-Identifier, trier et compter les pièces avant d'essayer d'assembler

-Les goujons de compression sont taraudés avec un Marteau

-Les glissières sont marquées d'un R (droit) et d'un L (gauche) pour un bon placement

-Assurez-vous toujours de faire face la pointe situé sur le haut de la Serrure de Came vers le bord extérieur

-Utiliser tous les clous fournis pour le panneau arrière et les répartir également

-Le panneau arrière doit être utilisé pour vous assurer que votre appareil est robuste

-N'utilisez pas de produits chimiques agressifs ou de nettoyeurs abrasifs sur cet appareil

-Ne jamais pousser, tirer, ou faire glisser votre meuble

Avant de Commencer (page 3)

-Lisez attentivement chaque étape et suivez le bon ordre

-Séparez et comptez toutes vos pièces et matériaux

-Donnez-vous suffisamment de place pour l'assemblage

-Avoir les outils suivants: tournevis à tête plate, #2 tournevis Phillips, et Marteau

-Attention: Si vous utilisez une perceuse électrique ou un tournevis électrique pour visser, veillez à ralentir et arrêter lorsque la vis est bien serrée. Le non-respect de cette consigne peut endommager la vis.

Système de Fixation de Came (page 3)

Ce Système de Fixation de Came sera utilisé tout au long de l'assemblage

Page 21

IMPORTANT ! LES PANNEAUX ARRIÈRE SONT UNE PARTIE STRUCTURELLE DE CE MEUBLE ET DOIVENT ÊTRE INSTALLÉS CORRECTEMENT.

Retournez soigneusement votre meuble sur sa face avant.

Fixez les panneaux arrière comme indiqué en clouant directement dans les bords bruts.

IMPORTANT ! Ne clouez pas la rangée centrale tant que le panneau arrière inférieur n'est pas installé, car les panneaux arrière se chevauchent.

Assurez-vous que notre meuble est carré.

La distance d'un coin à l'autre doit être égale, comme indiqué.

Alignez le bord inférieur du panneau arrière inférieur avec le bord inférieur du fond (F).

Page 26

Fixez d'abord les glissières, puis la poignée.

Page 27

Tout d'abord, placez vos tringles à l'endroit où vous souhaitez les positionner en ligne avec les trous du meuble et marquez l'emplacement des trous sur le mur. Ensuite, si vous utilisez les ancrages pour fixer les tringles de placard, insérez-les solidement dans le mur en les vissant à l'aide d'un tournevis. Ensuite, utilisez la vis #A12700 pour fixer vos tringles de placard à votre meuble, comme indiqué sur le côté gauche du meuble. Veuillez noter que la tringle de placard inférieure peut être placée d'un côté ou de l'autre du meuble. Ensuite, fixez les tringles de placard au mur à l'aide de la vis #A13020.

Page 28

Remarque : les trous des supports de tiroir sont fendus. Les façades des tiroirs peuvent être ajustées en desserrant les vis, en effectuant les ajustements nécessaires et en resserrant les vis.

Page 30

Pour la maçonnerie, le béton ou d'autres matériaux muraux :

Consultez votre quincaillerie locale pour obtenir des ancrages appropriés afin de fixer solidement le support de sécurité.

IMPORTANT : CE MEUBLE DOIT ÊTRE FIXÉ AU MUR POUR ÉVITER LE BASCULEMENT. SUIVEZ CES INSTRUCTIONS POUR INSTALLER LE SUPPORT DE SÉCURITÉ ANTI-BASCULEMENT FOURNI AVEC CE PRODUIT.

AVERTISSEMENT

Le basculement d'un meuble peut entraîner des blessures graves ou mortelles par écrasement.

Pour éviter le basculement :

- * Installer le dispositif de sécurité anti-basculement prévu
- * Placez les articles les plus lourds dans les tiroirs les plus bas
- * Ne posez pas de téléviseur ou d'autres objets lourds sur le dessus du meuble, à moins qu'ils n'aient été spécifiquement conçus à cet effet

- * Ne permettez jamais aux enfants de grimper ou de s'accrocher aux tiroirs, aux portes ou aux étagères
- * N'ouvrez jamais plus d'un tiroir à la fois

L'utilisation de dispositifs antibasculement peut seulement réduire et non éliminer le risque de basculement.

OPTION 1 : Fixation dans un montant de mur (méthode préférée)

À l'aide d'un détecteur de montants, localisez un montant dans le mur. Placez votre meuble contre le mur, avec le support de sécurité aligné à cet endroit. Pour faciliter l'insertion de la vis, vous pouvez percer un trou pilote de 3 mm de diamètre à travers le support de sécurité dans le montant. Enfoncez la vis à travers le support de sécurité dans le montant du mur.

OPTION 2 : Fixation dans une cloison sèche

Placez votre meuble à l'endroit souhaité contre un mur et marquez le mur à travers le support de sécurité, puis mettez votre meuble de côté. Percez un trou de 3/16" de diamètre (5 mm) dans le panneau mural. Tapez sur l'ancrage mural dans le trou jusqu'à ce qu'il soit affleurant. Installez le meuble à l'endroit voulu et fixez le support mural à l'ancrage mural à l'aide de la vis.

Page 31

CHARGES MAXIMALES

Ce meuble a été conçu pour supporter les charges maximales indiquées. Le dépassement de ces limites de charge peut entraîner un affaissement, une instabilité, un effondrement du produit et/ou des blessures graves.

Avertissement : Risque de blessure pour les personnes -- ne pas placer un téléviseur sur ce meuble. Ce meuble n'est pas homologué pour être utilisé avec un téléviseur.

Page 32

Enregistrez votre produit pour recevoir les éléments suivantes:

- * Détails sur les nouvelles tendances - un aperçu sur les nouveautés
- * Sondages - avoir une voix au sein de notre communauté
- * Offres exclusives et codes promo
- * Service de pièces de rechange rapide et facile

Pour enregistrer votre produit, visitez systembuild.com

5 Étoiles

Visitez le site Web de votre détaillant local, évaluez votre produit acheté et laissez-nous quelques commentaires !

Nous tenons à offrir un grand "Merci" à tous nos clients pour avoir pris le temps d'assembler ce produit "Systembuild", et de nous donner vos commentaires précieux.

Merci